



HAL
open science

Mining robotics: Application of computer vision to the automation of a roadheader

Michel Devy, Jean-José Orteu, J.L. Fuentes-Cantillana, J.C. Catalina, A. Rodriguez, D. Dumahu, P. Villeneuve de Janti

► To cite this version:

Michel Devy, Jean-José Orteu, J.L. Fuentes-Cantillana, J.C. Catalina, A. Rodriguez, et al.. Mining robotics: Application of computer vision to the automation of a roadheader. *Robotics and Autonomous Systems*, 1993, 11 (2), pp.65- 74. 10.1016/0921-8890(93)90010-A . hal-01716473

HAL Id: hal-01716473

<https://laas.hal.science/hal-01716473>

Submitted on 23 Feb 2018

HAL is a multi-disciplinary open access archive for the deposit and dissemination of scientific research documents, whether they are published or not. The documents may come from teaching and research institutions in France or abroad, or from public or private research centers.

L'archive ouverte pluridisciplinaire **HAL**, est destinée au dépôt et à la diffusion de documents scientifiques de niveau recherche, publiés ou non, émanant des établissements d'enseignement et de recherche français ou étrangers, des laboratoires publics ou privés.

Mining robotics: Application of computer vision to the automation of a roadheader *

M. Devy ^a, J.J. Orteu ^a, J.L. Fuentes-Cantillana ^b, J.C. Catalina ^b, A. Rodriguez ^b,
D. Dumahu ^c and P. Villeneuve de Janti ^c

^a L.A.A.S.-C.N.R.S., 7, Avenue du Colonel Roche, 31077 Toulouse Cedex, France

^b AITEMIN, c/ Alenza, 1, 28003 Madrid, Spain

^c INERIS, Etablissement de Verneuil, BP 2, 60550 Verneuil-en-Halatte, France

Abstract

Devy, M., Orteu, J.J., Fuentes-Cantillana, J.L., Catalina, J.C., Rodriguez, A., Dumahu, D. and Villeneuve de Janti, P., Mining robotics: Application of computer vision to the automation of a roadheader, *Robotics and Autonomous Systems*, 11 (1993) 65-74.

Automation of mining operations involves the use of sensing, remote monitoring and control systems in order to confront a variety of situations and environmental conditions. The need of profitability of a mine sometimes requires that selective cutting be performed in order to separate rich ore from waste at the cutting stage. Basically, the problems to be solved are those of modelling an uncontrolled, changing mine environment and programming the machine to cut a pattern accordingly. We present in this paper how image segmentation and classification, 3-D scene perception and path planning can cooperate to solve such a complex problem as selective cutting.

Keywords: Mining robotics; Computer vision; Color texture; Calibration; 3-D reconstruction

1. Introduction

This work has been performed in the framework of a collaborative program, funded by the



Michel Devy received his degree in Computer Science Engineering in 1976 from ENSIMAG, a Grande Ecole in Grenoble, France. He received his Ph.D. in 1980 from Université Paul Sabatier in Toulouse on 'Protocol modelling for local area network'. Since 1980, he has worked in the Robotics and Artificial Intelligence group of LAAS-CNRS (Toulouse, France) on the application of computer vision in automation and robotics. He has been involved in numerous national and international projects on manufacturing applications or mobile robots. He is now head of the Perception Area in the Robotics Group of LAAS-CNRS and his main scientific topics concern perception for mobile robots in natural environments.

Commission of the European Communities; AITEMIN, LAAS-CNRS and INERIS have undertaken a research project to automate the cutting operation of a roadheader for selective cutting in an underground potash mine near Barcelona in Spain [7,12].



Jean-José Orteu was born in France in 1963. He graduated in 1987 from a French Grande Ecole (ENSERB, Bordeaux), which specializes in electrical and software engineering. Working in the Robotics and Artificial Intelligence group of LAAS-CNRS (Toulouse, France) on the application of computer vision to the automation of cutting in mines, he received his Ph.D. degree from Université Paul Sabatier in 1991. Interested in computer vision and automatic

control, he is now working as an Assistant Professor at the Ecole des Mines d'Albi-Carmaux, a new Grande Ecole, which specializes in process engineering.

* This paper has been presented at the ORIA '91 conference on 'Telerobotics in Hostile Environments', 11-12 December, 1991, Marseille, France.

Many types of mining require cutting to be performed in a selective manner for several reasons: different unloading points for rich ore and waste, cutting efficiency, roof support, and safety. The possibility of automating selective cutting is very interesting for the economic benefits, but requires an accurate and reliable 'face mapping'.

The system we describe is based on the use of computer vision to discriminate the different ore types found in the face (sylvinite, carnalite and salt). Using the information about the ore distribution, paths are then planned for the computer-controlled cutting tool.



J.L. Fuentes-Cantillana obtained his degree in Mining Engineering in 1978 from the School of Mines, Polytechnic University of Madrid, and his Ph.D. in 1992 from the same university. He started his professional career in underground coal mining (Carbones de Berga, S.A.), and in 1982 he joined AITEMIN, an Industrial Research Association active in mining and construction industries, where he is now Director of Systems. His field of interest has always focused on the research, development and implementation of automation, control and monitoring systems in the mining industry. He is an associated member of IEEE, and participates as expert and consultant in different research programmes of the European Community in the field of automation and information technologies. Mr. Fuentes-Cantillana has more than 40 papers and articles, most of them presented at international events.

Juan Carlos Catalina is head of the Area of Image Processing and Artificial Intelligence of AITEMIN since November 1992. The previous six years he was in charge of the Computer Vision development group of AITEMIN, where he was involved in national and international research projects on different applications of image processing and image analysis to Robot Perception, Coal Maceral Analysis, Wear Inspection, Ore Sorting, etc. Before that, he worked part-time as a student at AITEMIN and at Laboratorio Oficial Madariaga on different computer applications. He received his degree in Mining Engineering from the School of Mines of the Polytechnical University of Madrid in 1986, and is currently pursuing his Ph.D. in the same institution. His main interest topics are image management, processing and analysis, computer graphics and digital electronics.



Angel Rodriguez was born in 1958 in Oviedo, Spain. In 1984 he received his degree in Mining Engineering from the E.T.S.I. de Minas de Oviedo. He joined AITEMIN in 1985. His main activity fields are hardware design, both analog and digital, especially of electronic equipment for use in hazardous areas, and software for industrial control systems. He is now head of the Area of Electronics at AITEMIN.



Didier Dumahu was born in France in 1965. He graduated in 1989 from UTC-Compiègne (University of Technology of Compiègne) a French Grande Ecole, which specializes in computer science and process engineering. He integrated CERCHAR (French National Coal Board Research Establishment) in 1989 in a software development team working on on-line expert systems for automatic diagnosis of power plants. He is now Project Manager at INERIS, Institut National de l'Environnement Industriel et des Risques, and is involved in automatic diagnosis systems for mining machines.



Philippe Villeneuve de Janti graduated from Université de Paris and worked in the field of high energy physics at CERN (European Organization for Nuclear Research) in Geneva, and at Niels Bohr Institute in Copenhagen. In 1980 he received the Ph.D. degree in Physics, and has been appointed Assistant Professor at Université Pierre et Marie Curie in Paris. He joined CERCHAR Laboratories in 1983 and contributed to develop mining robotics in France, in collaboration with the French Coal Board and LAAS-CNRS, Toulouse. He is presently head of Automation and Electronics Department at INERIS, Institut National de l'Environnement Industriel et des Risques.



2. Description of the application

We present in this paper the solutions that have been chosen to perform selective cutting automation. These solutions go beyond the framework of our application and can be extended to any automation problem involving image processing. In the next section, we briefly describe the application. Then we focus on the new methods we have developed for computer vision in unstructured and hostile environments. Two problems have been particularly studied: the ore identification from color and texture attributes extracted from images of the face, and the calibration of cameras mounted on the road-header. Finally, we give information about the cutting planification needed to optimize the result of the selective cutting.

In Fig. 1 we show a typical cross-section of the different seams. The selectivity in the cutting operation is based on cutting and separately loading the sylvinite A and B seams (rich ore) and the intermediate salt (waste), cutting as little as possible from the carnalite roof (for roof support

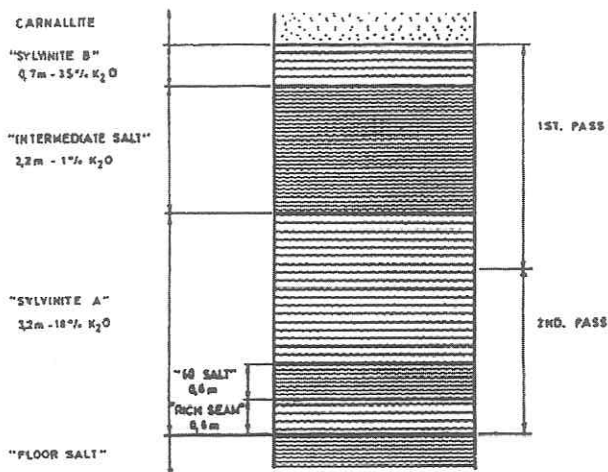

Fig. 1. Typical cross-section of the seams.

reasons) and the floor salt. The system must be able to recognize the mineral distribution at the face, producing a 'face map' which is used to determine the optimal cutting trajectory that should be performed in an automatic mode under

the system control. The objective is to fit a roadheader (see Fig. 2) with all of the sensors (cameras, angle sensors, etc.), actuators, control equipment and data processing capacity, and then, to automatically perform selective cutting operations at a typical face of the mine; the general organization of the system is shown in Fig. 3.

A precise description of the overall goals of the project and the test site can be found in [6]. During the current phase of the project we have two main objectives:

- on the one hand, show the feasibility and efficiency of computer vision as a tool for mineral recognition and face mapping [12];
- on the other hand, plane a strategy (path planning, job scheduling, etc.) to optimize the cutting operation, and control its execution by the use of the 2-dof arm which supports the cutting tool, the boom [7].

The problems of machine positioning and alignment in relation to the face have not been covered by this project; nevertheless, we want to

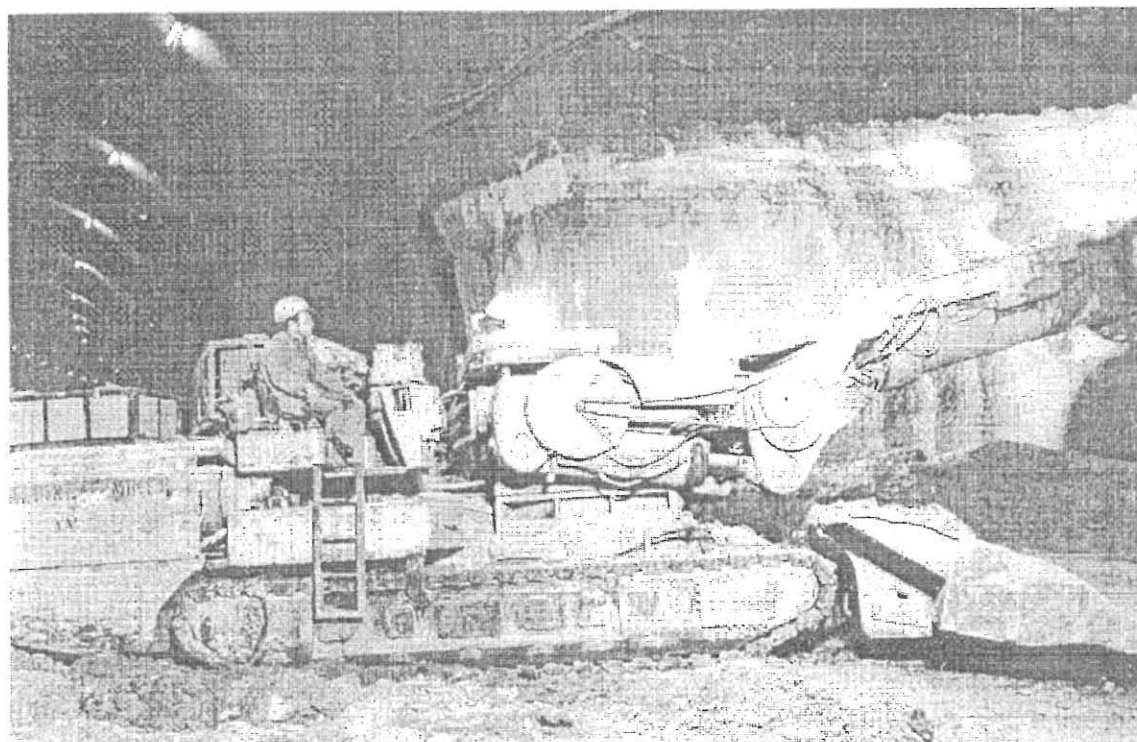

Fig. 2. Roadheader Alpine AM-100 in action.

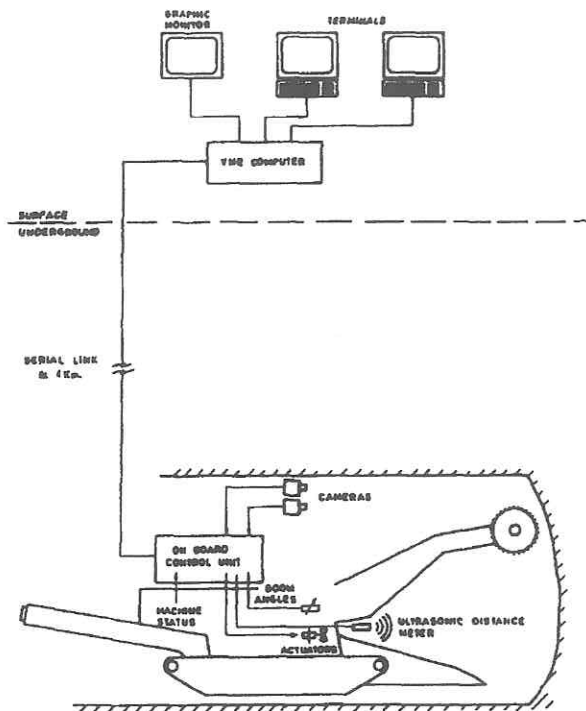

Fig. 3. System configuration.

automate the cutting operation, at least at a basic level, to evaluate the mapping efficiency and to detect operational requirements and problems that could be studied during another phase of the project.

This automatic selective cutting operation will be as follows. Once the machine has been put into position in front of the face (the cutting head just touching the face), the system will perform the image acquisition and processing tasks: geometric distortion correction, image fusion, ore recognition and face mapping. Then the cutting plan is generated; at first, the machine will move forwards, in order to cut the penetration slot from side to side. Geometrical transformations will be applied based on angle and distance sensors values to take into account the new position and attitude of the machine, and to correct the cutting plan. Then the system is ready to start cutting, from the penetration slot to the limit of the face, in a sequence computed previously in the plan in order to optimize selectivity. Note that the presence of dust during the cutting operation makes it impossible to obtain any image after the cutting has started.

3. Ore recognition

Human workers seem to achieve the recognition of the different ores present in the face by using the *color* information (sylvinite has a more 'red' aspect than salt, which is rather orange or white) and the *texture* information (the seams of sylvinite present an important stratification).

We have tackled the problem as a pattern recognition one. Each pixel of the image is represented by a set of features (vector \vec{x}) and the classification is obtained using a Bayes classifier. If we assume that the class conditional probability density for class C_k is multivariate Gaussian with mean \vec{m}_k and covariance matrix Σ_k and the *a priori* probabilities are equal for all classes, then the classification can be achieved by use of the discriminant functions:

$$f_k(\vec{x}) = (\vec{x} - \vec{m}_k)' \Sigma_k^{-1} (\vec{x} - \vec{m}_k) + \log |\Sigma_k|.$$

For each class C_k , a set of training observations whose class membership is known allows to determine parameters for the discriminant function $f_k(\vec{x})$; the Bayes decision rule classifies a point to class C_k if and only if:

$$f_k(\vec{x}) < f_s(\vec{x}) \quad \text{for all } k \neq s.$$

The key point of such an approach lies in the choice of the features which must be as discriminant as possible to lead to a good classification result. We extract color and texture features by the following methods:

- *Color features*

In order to design the most effective image processing based on color characteristics, a preliminary spectral analysis has been implemented on a set of mineral samples requested from the mine [6].

The study concluded that a discrimination between the ores could be achieved by computing at every point of the face the ratio:

$$k = \frac{\text{reflectance at } 625 \text{ nm} \pm 25 \text{ nm}}{\text{reflectance at } 525 \text{ nm} \pm 25 \text{ nm}}.$$

To put this analysis into practice, since 525 nm and 625 nm match closely the green and red filters of a color CCD camera, we have approximated the k ratio by dividing point by point the red and green planes of a color image (image called 'R/G'). Fig. 4 shows a color

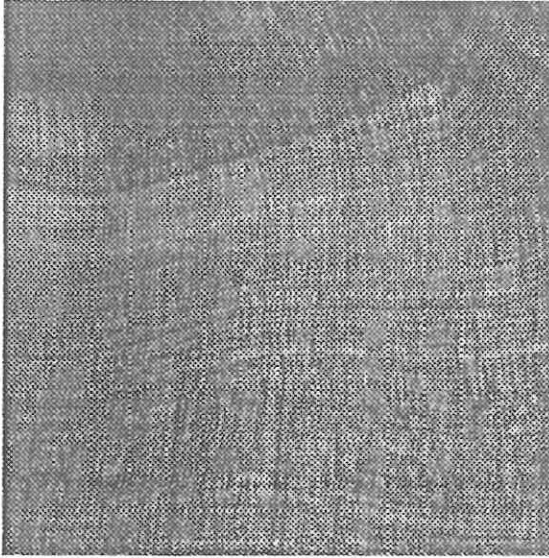

Fig. 4. A color image of the face.

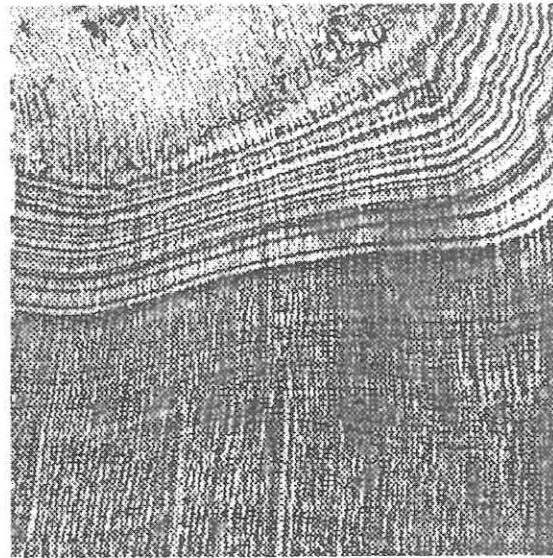

Fig. 5. R/G image from Image 4.

image of the face and Fig. 5 shows the corresponding red/green image.

The R/G feature has been added to more classical color features such as (R, G, B, r, g, b, I, H, S)¹ and a discriminant analysis has shown that (r, g, R/G) were the best features for discrimination [11].

- *Texture features*

We use an easy to compute texture extraction technique inspired by Laws' method [9]. First, microtexture features are obtained by filtering the input image with Laws' convolution masks, one for detection of horizontal stratifications, which are the most frequent in the mine, and the two others for detection of slanted stratifications. The relevant information for texture discrimination is present as the image variance of the microtexture features, computed over a 15×15 moving-window. Fig. 6 shows the texture image obtained from Image 5.

As a method of classification we have chosen a 'region classification' approach, which needs a preliminary region segmentation algorithm, performed with the well-known split-and-merge algorithm [8] using color uniformity predicates [1].

A region classification algorithm is applied to each region provided by the initial segmentation: each pixel of a given region is classified thanks to a Bayes classifier applied to the estimated feature vector \vec{x} of this pixel; the label of the most frequently occurring class is assigned to that region.

Such a labelling process can cause the merging of adjacent regions if they are given the same label; so, we provide significant improvements of the initial segmentation, like in a split-merge approach [4,10].



Fig. 6. The texture information from Image 5.

¹ r, g and b denote normalized color. I, H, and S denote intensity, hue and saturation.



Fig. 7. Split and merge on Image 4.

In a first step, we have discarded texture information because: (i) texture is known to be time consuming, (ii) stratification detection requires high resolution cameras. Nevertheless, with an 'only color approach' (results reported in [11]), numerous problems of missclassification can occur. *Figure 7* shows the result of applying the split and merge algorithm on Image 4 and *Fig. 8* shows the result of classifying the regions on color attributes. Taking into account the texture

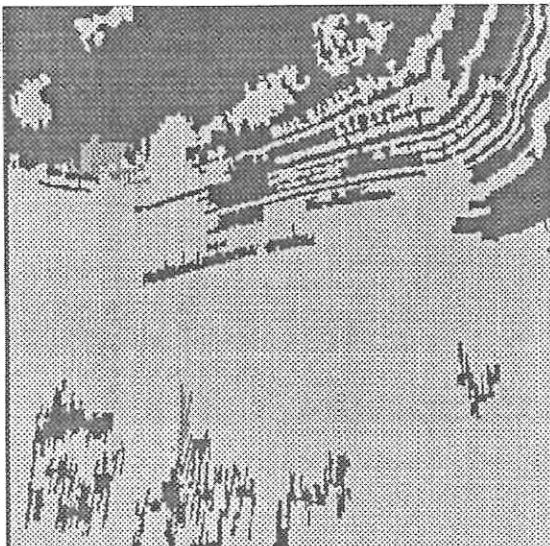

Fig. 8. Classification of the regions of Image 7 on color features.



Fig. 9. Classification of regions of Image 7 after adding the texture feature.

feature has brought a significant improvement, as shown in *Fig. 9*.

As can be seen in this figure, a seam of carnalite has been identified at the bottom of the image which is impossible according to the composition of the deposit. Such a mistake can be easily identified, using contextual information in order to guide the segmentation process.

An important problem we must cope with in order to apply this approach, is the choice of good cameras. To detect stratification, thin seams (only a few centimeters thick) have to be isolated from each other, on a broad face (7 m high, 7 m wide). This simultaneously requires a *large view field* and *high resolution* cameras. We cannot use 3-CCD color cameras in a hostile environment such as a mine. So, we must use 1-CCD cameras: they will be equipped with larger lenses to provide a better resolution. As the view field is reduced by such a choice, we must mount on the roadheader a set of cameras providing overlapping images that will be fused using the method proposed hereafter to provide a single view of the whole face.

4. 3-D scene perception

Once the image is segmented, we must produce a 'face map' that can be used to control the

cutting boom as determined by the ore distribution; the aim of the 'face map' is to give the face mineral's map in a coordinate system fixed to the roadheader. First of all, we must be able to determine the relationship between the 3-D coordinates of a point in the face and the corresponding 2-D coordinates of its image; the modelling of the perspective transformation of the camera is required.

4.1. Model of camera

We have chosen a camera model derived from the classical pinhole model to which we have added quadratic terms related to radial distortion. Calling (u_d, v_d) the distorted image coordinates and (X_m, Y_m, Z_m) the 3-D coordinates,² the camera model can be written:

$$u_d = f(X_m, Y_m, Z_m); \quad v_d = g(X_m, Y_m, Z_m). \quad (1)$$

The estimation of $f()$ and $g()$ requires the calibration of 11 parameters: 5 intrinsic parameters that characterize the inherent properties of the camera and optics, 6 extrinsic parameters (3 for the rotation and 3 for the translation) that indicate the position and orientation of the camera with respect to the machine coordinate system.

We have tackled the problem as a non-linear constrained optimization problem which we have solved using the algorithm of Levenberg-Marquardt; a set of (2-D position, 3-D position) pairs is used to estimate the $f()$ and $g()$ functions that match best Eq. (1). Our calibration method requires the knowledge of a set of non-coplanar points [3,5] in a reference coordinate system, here the roadheader frame.

4.2. Calibration using two optical theodolites

Usually, those points are obtained from a calibration target, but in a mine it seems very difficult to use such a method. So, an important point is to design an experimental method of calibration adapted to the hostile conditions of the mine. We have decided to create artificial marks on the machine that can be easily detected in an

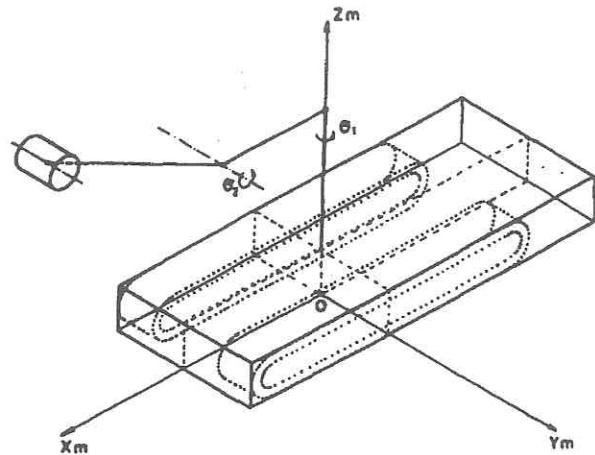

Fig. 10. The machine coordinate system.

image. The problem is to locate those points in the roadheader frame (see Fig. 10).

The marks on the machine could be located in this frame according to the *mechanical drawings supplied by the manufacturer* of the roadheader. We preferred to measure the Cartesian position of the marks in the roadheader frame by means of *two optical theodolites*; we do not use theodolite with associated distancemeter because the accuracy of the depth measure using the distancemeter relies on the nature of the surface which is aimed; we could use specific targets (prism provided by the theodolite manufacturer, or special material designed to perform omnidirectional reflections), but it seems very difficult to mount such specific targets on the roadheader for the experiment in situ.

The solution we propose [12] does not use on-the-shelf procedures to compute 3-D position of points (like in [2]), but takes into account the characteristics of the system we have to model: cameras on a roadheader. We describe hereafter the three steps of the calibration experiment:

- first of all, the system composed of the two theodolites is calibrated in order that the four angles measured by the theodolites permit to calculate the 3-D position coordinates of all desired points with respect to a theodolite frame;
- then, to locate those same points in the roadheader frame, we need to obtain the location of this frame with respect to the theodolite frame;

² The 3-D coordinates are expressed in the 3-D coordinate system fixed to the roadheader.

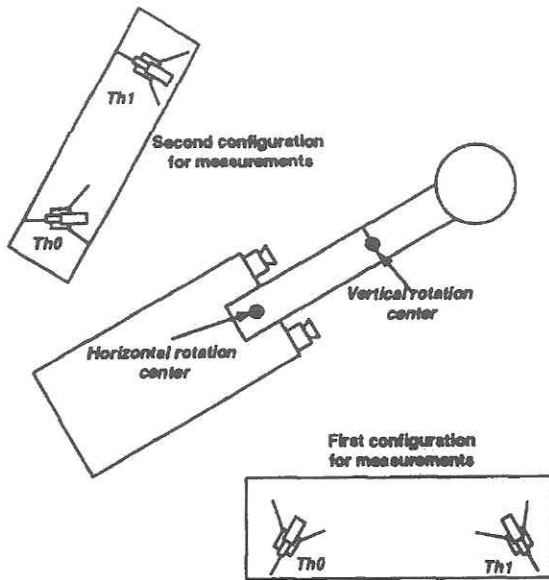

Fig. 11. Configuration for the two calibration experiments.

- last, to perform the calibration method for the estimation of the camera parameters, we require a set of matchings between pixels located in the image frame and non-coplanar points located in the roadheader frame, using the theodolites' measures.

We show hereafter results provided by an experiment in situ; in order to calibrate the four cameras mounted on the machine, we require two separated series of measurements from each side of the roadheader. For each one we calibrate the theodolite system and the transform between the theodolite frame and the roadheader frame (see Fig. 11). Then we cope with the cameras' calibrations which are obtained with the matching of 3-D points in the roadheader frame and their 2-D images by the different cameras.

Fig. 12 represents the 3-D results computed in the roadheader frame which are obtained with the two series of measurements. In this figure we have represented the roadheader frame, the reference theodolite frames for each experiment, two camera frames, and the 3-D data points.

4.3. Face mapping and image fusion

Once the cameras are calibrated, we can transform a face image into a face map in the roadheader machine coordinate system. All interesting 3-D points lie on the face; the most conve-

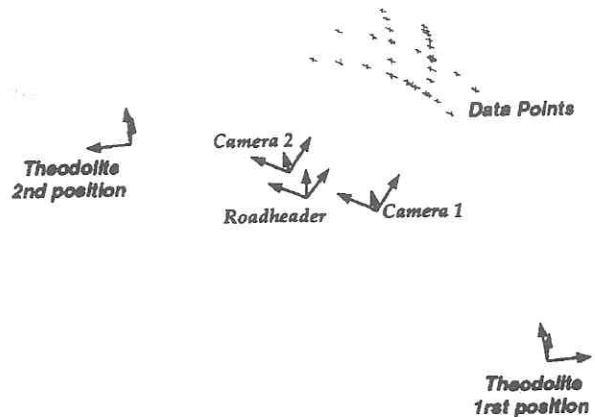

Fig. 12. Final result of the experiment in situ.

nient choice to refer to each one are the joint coordinates (θ_1, θ_2) of the roadheader boom (see Fig. 13). This system would make trajectory planning easier, as the boom is controlled using these coordinates.

We know that the face is a portion of a torus, and the equation of the torus

$$(X_m, Y_m, Z_m) = F(\theta_1, \theta_2) \quad (2)$$

is known in a coordinate system fixed to the roadheader. We discretize the values that (θ_1, θ_2) can take (sampling interval is 0.2 degrees); for each 3-D point obtained, we compute, using Eqs. (2) and (1), the corresponding (u_d, v_d) image point and put in position (θ_1, θ_2) of the 'face map' we are constructing the pixel value located in (u_d, v_d) .

In order to cope with image resolution, it is necessary to set up many cameras at different safe locations in such way that they cover areas

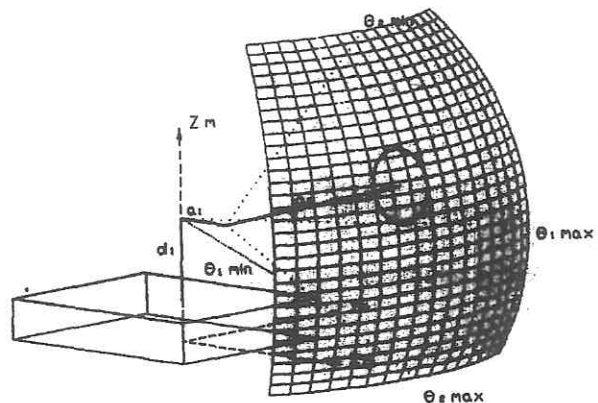

Fig. 13. The face is a portion of a torus.

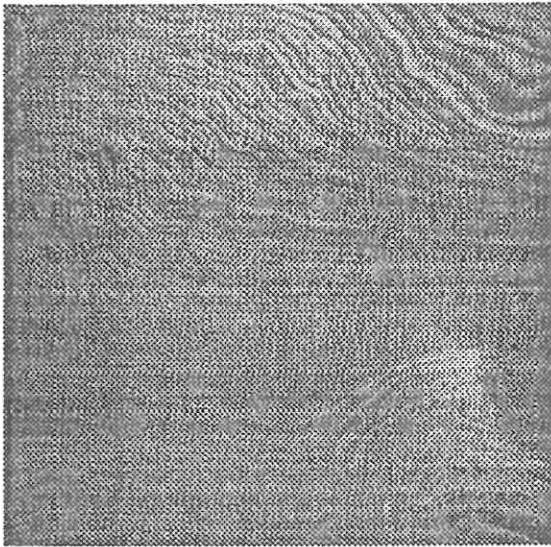

Fig. 14. Left image.

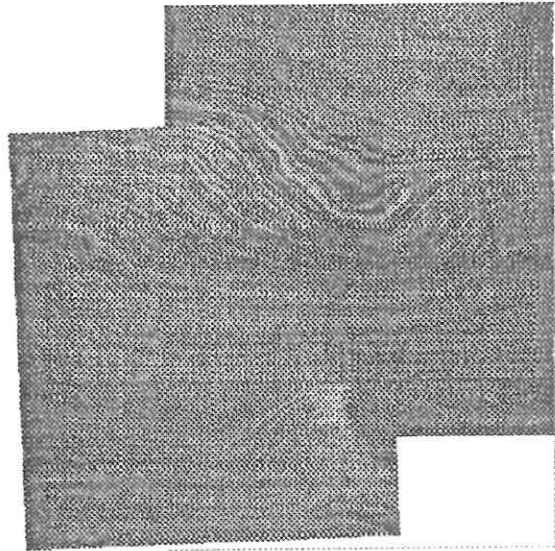

Fig. 16. Fused image.

which complement each other. As a result, the data from many cameras, located at different positions, has to be combined into a single face map.

The problem of image fusion is solved naturally from the construction of the face map; from a given point of the face, corresponding to a discrete value (θ_1, θ_2) , we compute, using Eqs. (2) and (1) for each camera c_i mounted on the machine, the corresponding image coordinates (u_d, v_d) ; if this point is seen from more than one camera, the pixel value we put in the face map is

the mean of the pixel values found in the corresponding image coordinates.

Figures 14 and 15 show two parts of the same scene taken by two cameras and Fig. 16 shows the result of combining them into a single image.

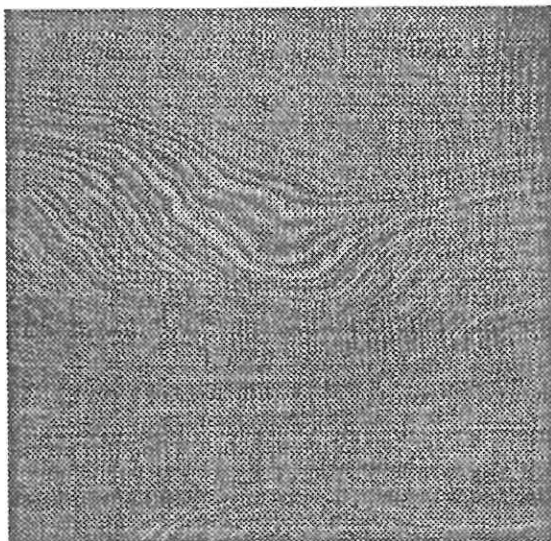
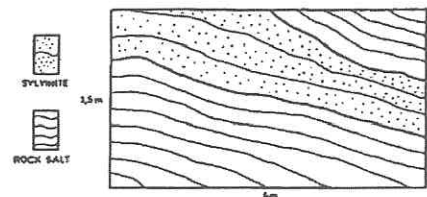
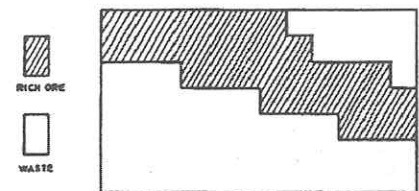

Fig. 15. Right image.



a) Face Mapping.



b) Interface Definition and Block Division

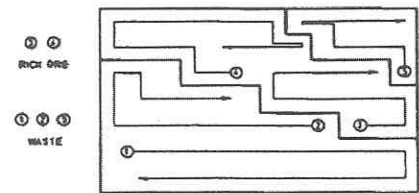

c) Cutting Trajectory Decision.

Fig. 17. Example of cutting planification.

5. Cutting planification

Once the face map is produced, a module generates the most adequate cutting trajectory, which is in principle different for every new cut. This module takes into account the desired final profile, roadheader operational limitations, and requirements of the loading procedure (shuttle car capacity). By now, no optimization criteria have been introduced in the operational planning, although the produced trajectory is intended to be an 'efficient' one. As an example, Fig. 17 shows a face map, boundaries redefinition according to the boom limitations and cutting plan generated for waste and for rich ore; the penetration slot is not taken into account in this example.

6. Conclusions

In this paper, we have presented an application of computer vision for the automation of cutting operations in a potash mine. We have shown that color and texture information is important for mineral identification. The two kinds of information cooperate in an automatic image classification algorithm which has been validated on many images of the mine face.

At this point of our work on the 'ore identification' problem, many improvements can be done to make the process more robust: particularly, the segmentation should be directed by the *a priori* knowledge we have on the application. For instance, we know that from roof to floor, the sequence of minerals is always *carnalite*, *sylvinitite B*, *intermediate salt*, *sylvinitite A* and *salt*. A new segmentation method has been developed by the Spanish partners (AITEMIN) using the contextual knowledge.

We have also presented a general method of calibrating cameras *in difficult environmental conditions* by means of two optical theodolites used as a triangulation system to perform 3-D measurements. This method has been successfully applied *in situ*, but we are sure that the solution we propose goes beyond the framework of our application and can be used for any camera calibration problem.

An integrated experiment involving vision, path planning for the boom trajectory and cutting op-

eration will be done during the next months in order to demonstrate the validity of such technology in very hostile environments.

Acknowledgment

This project has been funded since 1988 by EEC, DG XII, Research Action Program 'Primary Raw Materials', technical area 'Mining Technology'.

References

- [1] T. Baron, De la perception à la modélisation par la vision achrome et trichrome en robotique, Thèse de l'Université Paul Sabatier, Toulouse (France), Laboratoire d'Automatique et d'Analyse des Systèmes (C.N.R.S.), 1991.
- [2] J.L. Caenen and J.C. Angue, Robot calibration, *11th International Symposium on Industrial Robots (ISIR)*, Tokyo, (1989).
- [3] F. Chaumette and P. Rives, Modélisation et calibration d'une caméra, *7ème Congrès AFCET Reconnaissance des Formes et Intelligence Artificielle*, Paris (1989) 527-536.
- [4] M.F. Doherty, C.M. Bjorklund and M.T. Noga, Split-merge-merge: An enhanced segmentation capability, *Proc. IEEE Conference on Computer Vision and Pattern Recognition*, Miami Beach, FL (1986) 325-330.
- [5] O.D. Faugeras and G. Toscani, Camera calibration for 3D computer vision, *International Workshop on Machine Vision and Machine Intelligence*, Tokyo (1987) 240-247.
- [6] J.L. Fuentes-Cantillana, J.C. Catalina, J.J. Orteu, A. Rodriguez and D. Dumahu, Use of computer vision for automation of a roadheader in selective cutting operation, *International Symposium on Mine Mechanization and Automation*, Golden, CO (1991).
- [7] J.L. Fuentes-Cantillana, C. Fernández and J.J. Sánchez, Robotization of a Roadheader for Underground Works, *23rd International Symposium on Industrial Robots (ISIR)*, Barcelona (1992).
- [8] S.L. Horowitz and T. Pavlidis, Picture segmentation by a tree traversal algorithm, *Journal of the Association for Computing Machinery (ACM)* 23 (2) (1976) 368-388.
- [9] K.I. Laws, Rapid texture identification, *SPIE* 238 (1980) 376-380.
- [10] J.J. Orteu, J.C. Catalina and M. Devy, Perception for a roadheader in automatic selective cutting operation, *IEEE International Conference on Robotics and Automation*, Nice (1992).
- [11] J.J. Orteu and M. Devy, Application of computer vision to automatic selective cutting with a roadheader in a potash mine, *5th International Conference on Advanced Robotics (ICAR)*, Pisa (1991).
- [12] J.J. Orteu, M. Devy and T. Baron, Mining robotics: 3D perception of a roadheader for the automation of cutting operation, *23rd International Symposium on Industrial Robots (ISIR)*, Barcelona (1992).