



**HAL**  
open science

# Energy-Harvesting Powered Variable Storage Topology For Battery-Free Wireless Sensors

Firdaous El Mahboubi, Marise Baffleur, Vincent Boitier, Jean-Marie Dilhac

► **To cite this version:**

Firdaous El Mahboubi, Marise Baffleur, Vincent Boitier, Jean-Marie Dilhac. Energy-Harvesting Powered Variable Storage Topology For Battery-Free Wireless Sensors. International Conference on Modern Circuits and Systems Technologies (MOCASST) on Electronics and Communications, May 2018, Thessaloniki, Greece. 10.1109/MOCASST.2018.8376624 . hal-01747946

**HAL Id: hal-01747946**

**<https://laas.hal.science/hal-01747946v1>**

Submitted on 29 Mar 2018

**HAL** is a multi-disciplinary open access archive for the deposit and dissemination of scientific research documents, whether they are published or not. The documents may come from teaching and research institutions in France or abroad, or from public or private research centers.

L'archive ouverte pluridisciplinaire **HAL**, est destinée au dépôt et à la diffusion de documents scientifiques de niveau recherche, publiés ou non, émanant des établissements d'enseignement et de recherche français ou étrangers, des laboratoires publics ou privés.

# Energy-Harvesting Powered Variable Storage Topology For Battery-Free Wireless Sensors

F. El Mahboubi, M. Bafleur, V. Boitier, J-M. Dilhac

LAAS-CNRS, Université de Toulouse, CNRS, INSA, UPS, Toulouse, France

Email: [felmahbo@laas.fr](mailto:felmahbo@laas.fr)

**Abstract**—This paper presents a novel energy storage architecture aimed at providing the energy autonomy of battery-free wireless sensors powered by energy harvesting. It is based on a concept of adaptive storage using ultra-capacitors and allows meeting contradictory compromises: fast initial startup (small capacitance value) to be able to supply the load as quickly as possible, storage of a large amount of energy (big capacitance value) to increase the energy autonomy of the load and providing a pre-regulated voltage. Compared to previously published structures, the proposed architecture is much less complex and exhibits 92% energy utilization efficiency.

**Keywords**— *Energy harvesting, autonomy, variable energy storage, ultra-capacitors, wireless sensor.*

## I. INTRODUCTION

The energy autonomy of wireless sensors is one of the main roadblocks to their wide deployment. A way to strengthen the energy autonomy of these systems is to use energy harvesting from the surrounding environment coupled to a storage unit. Moreover, getting rid of primary batteries to avoid costly maintenance would be a must. Compared to batteries, ultra-capacitors provide an interesting alternative for energy storage in applications where a long service lifetime is required or in severe environments (extreme temperatures) with the additional advantage of not presenting safety issues.

However, this type of storage has some drawbacks and requires a compromise to satisfy two important objectives: a sufficient voltage during the initial charge must be rapidly reached (small capacitance) to get the powered system operational as quickly as possible and a large amount of energy should be stored (big capacitance) to increase its energy autonomy. A self-adaptive storage architecture consisting of 4 ultra-capacitors was already proposed to address these constraints [1]. This structure is based on reconfiguring the storage elements from all in-series to all in-parallel and reversely according to the availability of harvested energy and to the load consumption. This autonomous adaptive storage strategy allows a fast start-up and an increase energy usage (~10%). However, it does not provide a pre-regulated voltage and induces abrupt voltage changes upon capacitor switching that could induce unwanted perturbations. We propose a variable storage topology constituted of only two ultra-capacitors, a small value one ( $C_{small}$ ) and a large value one ( $C_{big}$ ) that are appropriately switched to provide both fast

start-up of the system to be powered, large energy storage, output voltage pre-regulation and autonomy of the system.

## II. BASIC OPERATION PRINCIPLE

This adaptive storage system, aimed at supplying a wireless sensor node powered by ambient energy harvesting, is not new. Several solutions were already proposed in the literature: one needs a very large number of switches causing heavy losses [2], another requires a large number of ultra-capacitors [3], and a third one uses a complex architecture with multi-stacked dc-dc converters [4].

In this article, we propose an alternative and very simple self-adaptive energy storage architecture. We analyze and experimentally compare two different architectures. These adaptive systems are self-powered by an energy-harvesting source, that is the control logic is self-powered by the energy stored in the ultra-capacitors.

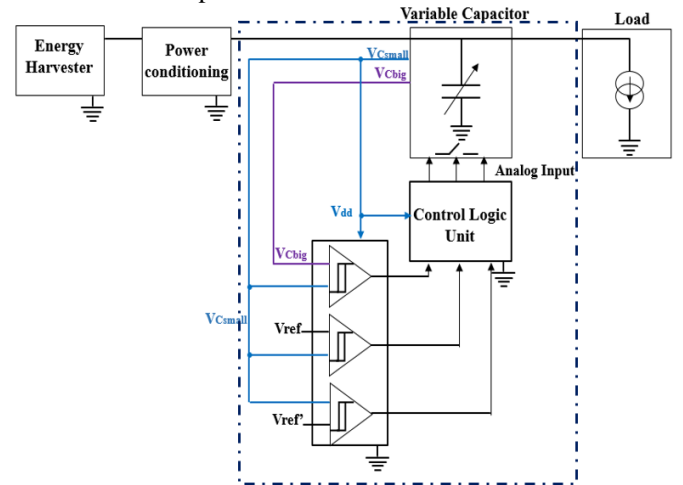

Figure 1: Block diagram of the proposed self-powered adaptive storage architecture (dashed-line block).

### A. Presentation of the first self-adaptive switched architecture storage with 4 ultra-capacitors

Regarding the first architecture already proposed [1], its principle is to use a matrix of four identical ultra-capacitors (UCs), interconnected by switches.

The architecture shown in Figure 2 is constituted of 4 identical ultra-capacitors (with capacitance  $C_i=100\text{mF}$ ),

9 switches and 3 Schottky diodes to allow a default serial structure at start-up.

During the charge phase, the change of the configuration depends on the state of charge of the ultra-capacitor connected to ground ( $V_{C4}$ ). This allows for three configurations:

- the first one “all in-series” allows a fast startup ( $C_{eq} = C_i/4$ ),
- the second configuration is “series-parallel”,
- and the third configuration is “all in-parallel” in order to maximize the amount of stored energy ( $C_{eq} = 4 C_i$ ) without increasing  $V_+$  voltage.

And conversely for the discharge phase, to reduce the equivalent capacitance of the architecture and use as much as possible the stored energy in ultra-capacitors.

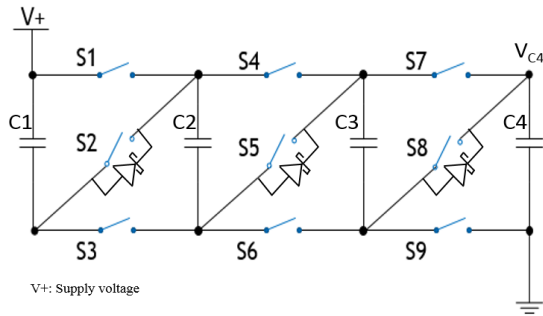

Figure 2: Configuration of the self-adaptive switched architecture for 4 UCs.

For sake of simplicity, this self-adaptive architecture storage does not include a balancing circuit, the maximum losses, related to the capacitance-value variability for a tolerance range of  $\pm 20\%$ , being 2% of the relative stored energy. The global losses including the required control electronics result in 91% energy storage efficiency. This autonomous structure insures a very fast start-up, stores a high amount of energy and provides a maximum energy usage rate. But it is quite complex. The purpose of the new proposed structure that is described in the following section is to reduce the complexity and at the same time, the power losses.

### III. SELF-VARIABLE STORAGE TOPOLOGY FOR 2 UCs

#### A. Circuit topology

The proposed storage topology in this paper is constituted of only two ultra-capacitors, a small value one ( $C_{small} = 100mF$ ) and a large value one ( $C_{big} = 400mF$ ) that are appropriately switched to provide both a fast start-up of the system to be powered, large energy storage and output voltage pre-regulation.

This topology presented in Figure 3 is very simple: it includes a Schottky diode to ensure the initial start-up of the small ultra-capacitor ( $C_{small}$ ) and 3 switches which allow the reconfiguration of the two ultra-capacitors with regard to the power supply and to the load. The Schottky diode provides a low threshold voltage and unidirectional flow for the current.

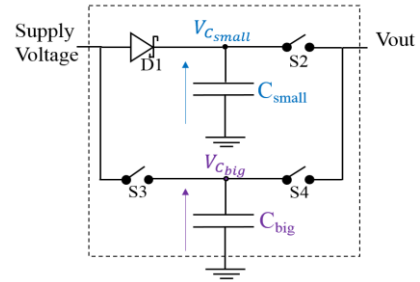

Figure 3: Configuration of the variable architecture with 2 UCs.

#### B. Operating principle

The principle of this variable storage architecture is to initially supply the small ultra-capacitor  $C_{small}$  across the Schottky diode D1, all the switches being open (normally-off). The main objective is to be able to supply the load as soon as possible.

First, when  $V_{C_{small}}$  reaches a sufficient voltage ( $\sim 1V$ ), the control circuitry is able to operate. The control circuitry monitors both the voltage across  $C_{small}$ ,  $V_{C_{small}}$  and the voltage across  $C_{big}$ ,  $V_{C_{big}}$ . In a second step, once  $C_{small}$  has stored enough energy for supplying the load, the control logic closes S2 switch to supply it (see Figs.4.a and b).

If the energy-harvesting source is sufficient,  $V_{C_{small}}$  can reach its maximum value and S3 switch is closed so as  $C_{big}$  can be charged (see Figure.4.c). This charge phase of  $C_{big}$  is stopped as soon as  $V_{C_{small}}$  decreases by 50mV.

The two cycles (c and b) are repeated, the load being supplied by  $C_{small}$ , until the two voltages  $V_{C_{small}}$  and  $V_{C_{big}}$  become equal. In this case, the architecture moves to a parallel configuration (see Figure.4.d) to maximize energy autonomy.

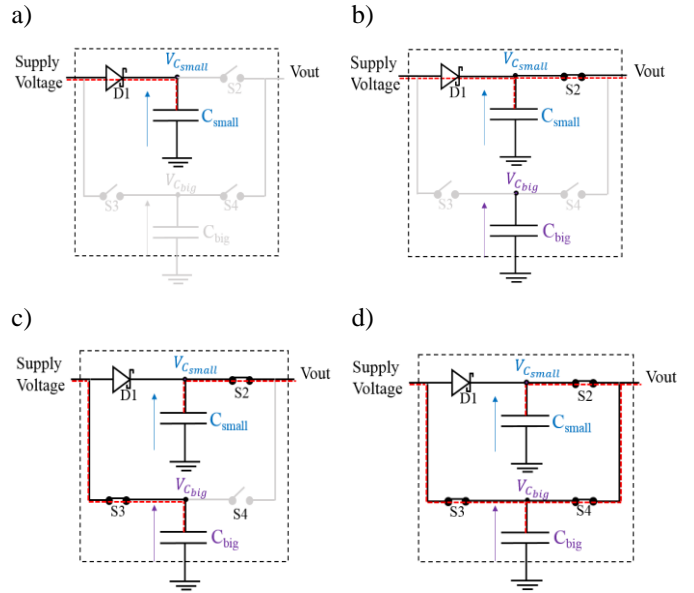

Figure 4: The different operation modes of the variable architecture.

#### IV. CONTROL PARAMETERS AND LOGIC ANALYSIS

$V_{C_{small}}$  represents the critical voltage for switching. At start-up,  $C_{small}$  is charging via the Schottky diode. Once  $V_{C_{small}}$  reaches  $V_{max1}$  (the minimum voltage for which the powered system can be operated), S2 closes. While supplying the load,  $V_{C_{small}}$  reaches  $V_{max2}$ , meaning that the energy-harvesting source is sufficient and that  $C_{big}$  can be charged. To do so, S3 switch is closed until  $V_{C_{small}}$  decreases down to  $V_{min2}$ . The cycle is repeated ( $V_{C_{small}} \geq V_{max2}$  or  $V_{C_{small}} \leq V_{min2}$ , see Figure 6), until  $V_{C_{small}} = V_{C_{big}}$ . If the energy source becomes insufficient, as soon as both ultra-capacitors get discharged down to  $V_{min1}$ , S2 switch is opened. To control these switched capacitors, we defined five different conditions:  $V_{C_{small}} \geq V_{max1}$ ;  $V_{C_{small}} \leq V_{min1}$ ;  $V_{C_{small}} \geq V_{max2}$ ;  $V_{C_{small}} \leq V_{min2}$ ;  $V_{C_{small}} = V_{C_{big}}$ .

That are implemented using 2 hysteresis comparators ( $V_{min1}$ ,  $V_{max1}$ ) and ( $V_{min2}$ ,  $V_{max2}$ ), and one comparator for the last condition.

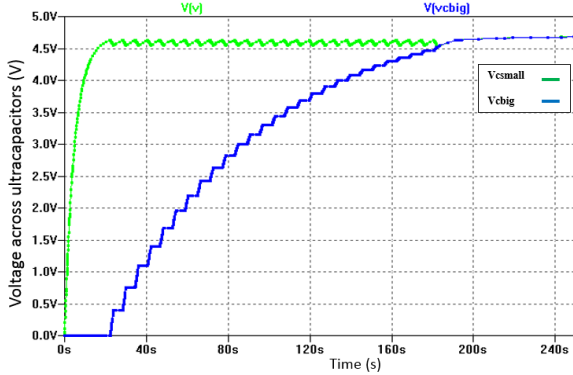

Figure 5: Simulated  $V_{C_{small}}$  and  $V_{C_{big}}$  voltages vs. time for the proposed adaptive storage architecture during charge and discharge while supplied by a Thevenin generator ( $E_{th}=5.1V$ ,  $R_{th}=50\Omega$ ,  $R_{LOAD}=1k\Omega$ ).

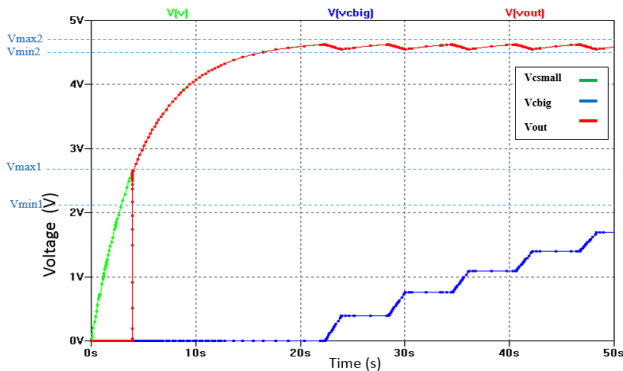

Figure 6: Zoomed view of Figure 5 over the start-up phase.

#### V. SIMULATION AND EXPERIMENTAL RESULTS ANALYSIS

To optimize the operating principle for this variable storage architecture, we performed electrical simulations. Then we realized the electronic circuit to experimentally validate these results.

To implement the architecture, we used commercially available components. This structure includes two ultra-capacitors AVX\_BestCap interconnected to the source and the

load by a Schottky diode (D1), and three ADG801 normally-off (S2, S3 and S4) CMOS switches.

The voltage across  $C_{small}$  allows powering the control circuitry made up of three comparators LT6700 and LTC1443, eight AND gates, two inverters and two logical OR gates driving the switches (see Figure 1).

##### A. Simulation results

We have simulated the proposed architecture using LTspice software. For the charging phase, we used a Thevenin generator made up of a  $50\Omega$  resistor and a  $5.1V$  voltage source to simulate an energy-harvesting source. For the discharge phase, we connected a  $1k\Omega$  resistor at the output.

During these two phases, we monitored the voltages at each intermediate node ( $V_{C_{small}}$ ,  $V_{C_{big}}$  and  $V_{out}$ , see Figures 5 and 6). The benefits of this variable architecture are: fast start-up and high rate of stored energy with output pre-regulation.

##### B. Prototype

A discrete prototype of the variable storage structure with 2 ultra-capacitors is shown in Figure.7.a. The electronic board on the top shows the adaptive storage architecture with  $C_{small}$  and  $C_{big}$  ultra-capacitors. The electronic board on the bottom shows the control logic of this architecture. Figure.7.b shows the prototype of the adaptive storage architecture with 4 ultra-capacitors.

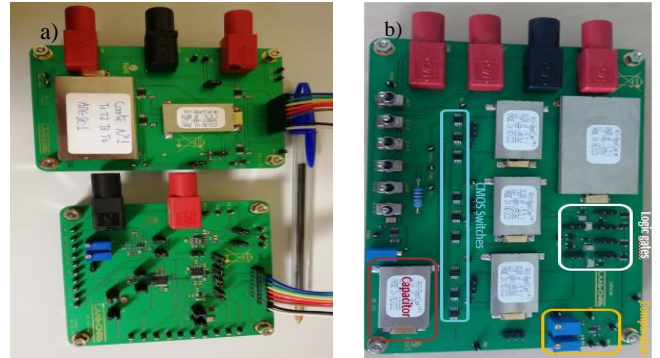

Figure 7: Prototypes of the two compared variable storage architectures: a) for 2 UCs and b) for 4 UCs also including a single-UC storage structure.

##### C. Comparison of experimental results

The concept of the proposed adaptive storage was first validated in simulation and then experimentally. The proposed structure is compared to the previously published 4-UCs adaptive storage structure and to a storage structure with a single UC.

The energy source is emulated by a Thevenin generator:  $E_{th}=5.1V$ ,  $R_{th}=50\Omega$ ,  $R_{LOAD}=1k\Omega$ ,  $C_{small}=100mF$ ,  $C_{big}=400mF$ . Figure 8 presents the experimental waveforms obtained during the charge and discharge phase. At starting, the ultra-capacitors are empty, the small ultra-capacitor charges firstly close to its maximum voltage. Then, once  $C_{small}$  has stored enough energy, it switches to his discharge phase for  $50mV$  in order to supply the load during this time, while  $C_{big}$  is charging.

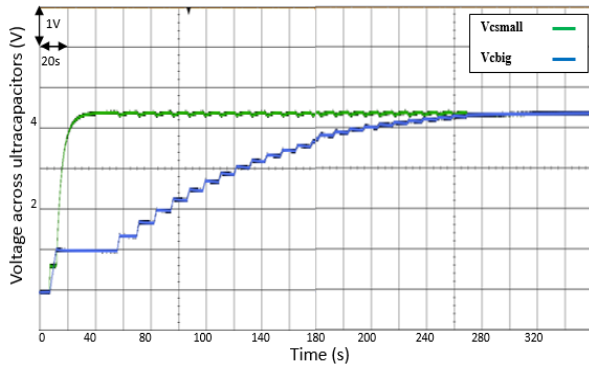

Figure 8: Measured  $V_{C_{small}}$  and  $V_{C_{big}}$  voltages vs. time for the proposed adaptive storage architecture during charge and discharge while supplied by a Thevenin generator ( $E_{th}=5.1V$ ,  $R_{th}=50\Omega$ ,  $R_{LOAD}=1k\Omega$ ).

For the same test conditions, the experimental results of charge phase of the adaptive storage architecture with 4 identical ultra-capacitors (with a capacitance value  $C=100mF$ ) are shown in Figure 9. The ultra-capacitors are empty and they are configured in series configuration (S). When  $V_{C4}$  voltage across the ultra-capacitor connected to ground reaches a maximum voltage threshold, then the adaptive storage architecture switches to a series-parallel (SP) configuration and finally to an all-parallel (P) one and conversely, in discharge mode, the switching to the next configuration being defined by a minimum voltage threshold.

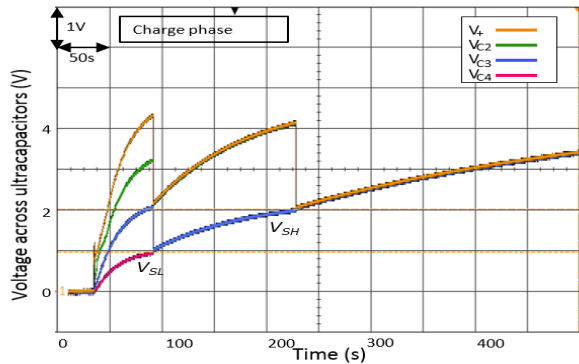

Figure 9: Measurement of the self-adaptive prototype storage for 4 identical SCs, during charge phase while supplied by a Thevenin generator ( $E_{th}=5.1V$ ,  $R_{th}=1k\Omega$ ,  $R_{LOAD}=1k\Omega$ ).

In the case of a capacitor of fixed value ( $C=500mF$ ), the load starts to be supplied at  $t=230s$ . The new variable architecture with 2 UCs is reaching rapidly the voltage threshold (1.6V) in 120s.

The architecture with 2 UCs is much simpler than the one with 4UCs in terms of: number of switches to be controlled (3 switches against 9), required number of ultra-capacitors (2 UCs against 4 UCs) and logic control complexity. In addition, when the energy source is sufficient regarding the load demand, it allows having a pre-regulation at the output. Anyway, in a final system, it will be needed to implement a simple voltage regulation such as an LDO regulator to cope with fluctuations induced by the temporary loss of the energy source.

The typical energy usage efficiency, computed as the ratio of consumed energy including measured losses to energy provided by the source is 92%. The total 8% losses are distributed over two categories: 2% related to the control logic, 6% to switches and ultra-capacitors (self-discharge current). This energy efficiency performance value favorably compares to the architecture with 4-UCs [1] (91%) and to the one described in [3] (88%), which are both much more complex.

The proposed variable storage architecture (with 2-UCs) is then a very interesting alternative to previously published adaptive structures in terms of: lower complexity, better/comparable energy usage efficiency and pre-regulated output voltage that should induce less electromagnetic interferences.

## VI. CONCLUSION

The principle of variable storage based on two ultra-capacitors, one of small value and a second of big value is validated. It exhibits a quick start-up, a significant amount of stored energy with output pre-regulation. Despite this latter property, in the same way as the 4-UCs structure, to correctly supply a wireless sensor node, at least an LDO regulator needs to be implemented at its output to manage the intermittency of the energy source. The losses related to the required control electronics result in 92% energy usage efficiency.

This adaptive storage building block can be integrated on silicon and combined to miniaturized microsupercapacitors [6] to provide a compact module. With this module coupled to an energy-harvesting source, it could be envisioned for a wireless sensor node to become fully battery-free.

## ACKNOWLEDGMENT

This work was partially carried out within the framework of the European project SMARTER funded by the CHIST-ERA program, "Green ICT, towards Zero Power ICT".

## REFERENCES

- [1] F. El Mahboubi, M. Bafleur, V. Boitier, A. Alvarez, J. Colomer, P.Miribel and J.-M. Dilhac, Self-Powered Adaptive Switched Architecture Storage, POWERMEMS 2016, Paris (France), December 6-9, 2016.
- [2] M. Uno, H. Toyota, Equalization technique utilizing series-parallel connected supercapacitors for energy storage system, in IEEE International Conference on Sustainable Energy Technologies, 2008. ICSET 2008, 2008, p. 893-897.
- [3] J.-F. Nie, X. Xiao, Z. Nie, P. Tian, and R. Ding, A novel three-level changeover circuit of super-capacitor bank for energy storage systems, in IECON 2012 - 38th Annual Conference on IEEE Industrial Electronics Society, 2012, p. 144-149.
- [4] M. Uno, K. Tanaka, Single-Switch Cell Voltage Equalizer Using Multistacked Buck-Boost Converters Operating in Discontinuous Conduction Mode for Series-Connected Energy Storage Cells, IEEE Trans. Veh. Technol., vol. 60, no 8, p. 3635-3645, oct. 2011
- [5] R. Monthéard, M. Bafleur, V. Boitier, J.-M. Dilhac and X. Lafontan, Self-adaptive switched ultra-capacitors: a new concept for efficient energy harvesting and storage, PowerMEMS, 2012, pp. 283-286.
- [6] N.A. Kyeremateng, T. Brousse, D. Pech, Micro-supercapacitors as miniaturized energy-storage components for on-chip electronics. Nature Nanotechnology, vol.12, pp. 7-15, (2017).