



HAL
open science

Enhanced chronicle learning for process supervision

John William Vásquez, Louise Travé-Massuyès, Audine Subias, Fernando Jimenez

► **To cite this version:**

John William Vásquez, Louise Travé-Massuyès, Audine Subias, Fernando Jimenez. Enhanced chronicle learning for process supervision. 20th IFAC WORLD CONGRESS, Jul 2017, Toulouse, France. pp.5191-5196. hal-01847010

HAL Id: hal-01847010

<https://laas.hal.science/hal-01847010>

Submitted on 23 Jul 2018

HAL is a multi-disciplinary open access archive for the deposit and dissemination of scientific research documents, whether they are published or not. The documents may come from teaching and research institutions in France or abroad, or from public or private research centers.

L'archive ouverte pluridisciplinaire **HAL**, est destinée au dépôt et à la diffusion de documents scientifiques de niveau recherche, publiés ou non, émanant des établissements d'enseignement et de recherche français ou étrangers, des laboratoires publics ou privés.

Enhanced chronicle learning for process supervision

J. W. Vásquez^{*,**} L. Travé-Massuyès^{*} A. Subias^{*}
F. Jimenez^{**}

^{*} LAAS-CNRS, Université de Toulouse, CNRS, INSA, Toulouse,
France.

e-mail: (jwvasque@laas.fr, louise@laas.fr, subias@laas.fr)

^{**} GIAP, Engineering department, Andes University
Bogotá, Colombia. fjimenez@uniandes.edu.co

Abstract: Process alarm management can be approached as a pattern recognition problem in which temporal patterns are used to characterize different typical situations, particularly at startup and shutdown stages. This paper focuses on learning the temporal patterns, in the form of chronicles, by extending the previously proposed Heuristic Chronicle Discovery Algorithm Modified *HCDAM*. The proposed extension incorporates knowledge, in particular in the form of so called *temporal runs*, to focus the learning process and produce less conservative chronicles. The resulting Chronicle Based Alarm Management (CBAM) approach is hence based on a diagnosis process which permits situation recognition and provides the operators with relevant information about the failures inducing alarms flows in the startup and shutdown stages. The event sequences that represent a process situation are generated by simulation and including *temporal runs*, the chronicles are extracted using the extended version of *HCDAM*. Finally, the conclusion and future work are presented.

Keywords: Alarm management, Diagnosis, Chronicles, Pattern recognition

1. INTRODUCTION

In industrial environments, it is common for the plant operators to perform their duties by silencing process alarms. This is so because these alarms are too numerous and become noise rather than helping to detect and diagnose abnormal situations. Currently, it is very easy to set alarms on modern electronic control systems, and operators are inundated with "alarms" that do not help them to perform their tasks but, on the contrary, hinder them (Stanley and Vaidhyanathan (1998)). However, the plant alarms should be administered according to: a philosophy that includes the purpose of the alarm system; procedures associated with the alarm system and other plant procedures; methods for prioritization; alarm classes; roles and operator responsibilities with respect to alarms; principles of the alarms; documentation required for each alarm; training; rates of key system performance; change management, and preservation of history of alarms (ISA 18.2).

The nature of alarms and other procedure actions makes that many of the aspects of industrial processes can be captured by discrete events. The supervision problem thus must fit the formal recognition of behaviors in the context of Complex Event Processing (CEP). This corresponds to developing reliable tools that support the analysis of event streams to recognize activities that can generate normal or abnormal situations in complex flows. The dynamics of a process can be represented by an approach that depicts the process behavior using the events that occurs. Then, identifying the transition from normal operation to abnormal operation corresponds to detect symptoms. For do this, the

systems must be monitored and the diagnostic algorithms are therefore based on observations that the system provides. It must have a sufficient set of strategically placed sensors, providing useful indicators. This information is then used to reconstruct the state of the system and this observations coupled with a diagnostic algorithm allow to introduce the concept of diagnosability. A system is diagnosable with a diagnostic algorithm if it detects with certainty the occurrence of faults in the system, and is able to discriminate them in finite time. The formal definition of diagnosability may be different if one is interested in continuous systems (Basseville (2001)) or discrete events (Pencolé (2004)). Diagnosability provides an efficient criterion to assess the relevance of the observations in each situation.

In this context, chronicles (Dousson (1996), Ghallab (1996)) have been applied in many diagnosis applications but one of the biggest difficulties is to obtain automatically a base of chronicles that represents each situation. To obtain relevant chronicles from a set of event sequences representing a given situation, it is often necessary incorporate expert knowledge. This paper enhances the results of the chronicle learning algorithm proposed in (Subias et al. (2014)) by incorporating expert knowledge in the form of temporal runs, as well as additional information that allows us to limit the conservatism of chronicles.

The paper is divided into 5 sections. After the introduction, Section 2 presents the chronicles representation with its formal concepts. Section 3 presents the learning approach. An extension of the *HCDAM* is described with

an example. In the section 4, a case study related with an illustrative application in the petrochemical sector is used to apply the tree steps of the CBAM. Finally, in Section 5 the conclusion and future work are presented.

2. CHRONICLE REPRESENTATION

A chronicle is a set of events linked by temporal constraints and the occurrence of which is subject to a certain context. A chronicle is expressed as a constraint graph in which events are represented by nodes and time constraints are the labels of the arcs that connect the nodes. Time is represented as a linearly ordered discrete set of instants, whose granularity is fine enough compared to the dynamics of the environment and the means of observation. The "Chronicle Recognition System" named CRS was introduced in Dousson (1996) and extended in Dousson (2002). A system of chronicles is composed of three parts:

- (1) A set of predicates
- (2) A set of temporal constraints concerning these predicates
- (3) A set of actions to apply when chronicle is recognized (optional).

The latter part is used to react following the recognition of a chronicle; for example, the reaction may be a maintenance operation. This part does not concern the subject of training and therefore is not addressed in the following. To recognize chronicles, CRS must detect all subsets of occurrences of events in the input stream. These subsets correspond to all the sets of patterns of the chronicle taking into account the various constraints that compose it. To achieve this result, CRS creates partial instances. A partial instance corresponds to a partial subset of the chronicle event pattern. It is only when this subset is complete that the chronicle is recognized.

2.1 Concepts and formalization

Before defining a chronicle, it is good to remember that it is based on the verification of time constraints. The check is directly inspired by a Simple Temporal Problem (STP) introduced by Dechter et al. (1991). The occurrence of different events in time represents the system's dynamics in a given situation. The concept of event type expresses a change in the value of a given domain feature or set of features. E expresses the set of all event types. Note σ an event type where $\sigma \in E$. We can thus define the concept of event.

Definition 1: An event e is defined as a pair $e = (\sigma, t)$, where $\sigma \in E$ is an event type and t is a variable of integer type called the event date.

Several events can have the same event type, but do not necessarily have the same date, for instance $e_1 = (a, 3)$ and $e_2 = (a, 6)$ are two events carrying the same type of event a .

A flow of activity generated by a system is represented by a sequence. A sequence consists of several events in an orderly manner, which leads us to the following definition:

Definition 2: A sequence is defined as an ordered set of events denoted $S = \{e_i\}$ where $i \in N$, $i = 1, \dots, l$ and

$t_i < (t_{i+1})$, $i = 1, \dots, l - 1$ where l is the length of the time sequence S .

An example of sequence representing an activity stream may be given by a sequence $S_1 = \{e_1, e_2, e_3, e_4, e_5, e_6\} = \{(a, 2), (b, 4), (c, 5), (a, 8), (b, 9), (a, 10)\}$ with $l_1 = 6$.

Finally, a chronicle is a set of event types associated with time variables and a set of temporal constraints between time variables.

Definition 3: A chronicle is defined as a triplet $C = (\xi, \mathcal{T}, \mathcal{G})$ such that:

- $\xi \subseteq E$. Where ξ is called the typology of the chronicle.
- \mathcal{T} is the set of temporal constraints of the chronicle.
- $\mathcal{G} = (\mathcal{V}, \mathcal{A})$ is a directed graph where:
 - \mathcal{V} represent the event types of ξ
 - The arcs \mathcal{A} represent the different time constraints between *event types*. The edge $i \rightarrow j$ is associated to the constraint $\tau_{ij} \in \mathcal{T}$

Considering the two events (e_i, t_i) and (e_j, t_j) , we define the time interval as the pair $\tau_{ij} = [t^-, t^+]$, $\tau_{ij} \in \mathcal{T}$ corresponding to the lower t^- and upper t^+ bounds on the temporal distance between the two event dates t_i and t_j . If the event e_2 occurs after e_1 , then it exists a directed link \mathcal{A} from e_1 to e_2 associated with a time constraint.

A chronicle $C = (\xi, \mathcal{T}, \mathcal{G})$ is recognized in a given sequence S when $\xi \subseteq \xi'$ (ξ' set of event types associated to S) and all temporal constraints \mathcal{T} are satisfied. $C_{inst} = (\xi, \mathcal{T}_v)$ where \mathcal{T}_v is a valuation of \mathcal{T} , is an instance of C .

3. LEARNING CHRONICLES

The chronicle exploration process corresponds in discovering all the chronicles, whose instances occur in a given sequence. In many cases, the same situation does not implies perfectly identical sequences. This is the reason of that *HCDAM* uses several sequences as input.

3.1 Learning chronicles with HCDAM

The algorithm *HCDAM* learns the chronicles, whose instances occur in all event sequences representing the same situation (Subias et al. (2014)). Given a set of sequences \mathbb{S} and a minimum frequency threshold, it finds all minimal frequent chronicles present in all sequences. The chronicle learning algorithm has the following three phases:

- (1) Filtering
- (2) Building a constraint database from the input sequences.
- (3) Generating a set of candidate chronicles.

3.1.1. Phase 1: The *filtering operation* is a preliminary process on sequences and it can be summarized as follows:

- Filter the event types that are not present in all input sequences \mathbb{S} : if $\exists S_k \in \mathbb{S}$ such as $\exists \sigma_i \notin S_k$, then remove σ_i from all the other sequences in \mathbb{S} .
- Filter on a given set of event types $\Psi = \{\sigma_1, \sigma_2, \dots, \sigma_r\}$ if we are only interested in those event types for the learning process.

3.1.2. *Phase 2:* Phase two builds a constraint data base \mathbb{D} by considering each pair of event types and its temporal constraints in a constraint graph with tree structure.

In this constraint tree, time constraints are nodes and arcs represent the relationship *is parent of* defined as:

Definition 5: A node $e_i[t^-, t^+]e_j$ corresponding to the time constraint between e_i and e_j is parent of $e_i[t'^-, t'^+]e_j$ if and only if $[t'^-, t'^+] \subset [t^-, t^+]$ and there does not exist $e_i[t''^-, t''^+]e_j$ such that $[t'^-, t'^+] \subset [t''^-, t''^+] \subset [t^-, t^+]$.

3.1.3. *Phase 3:* The generation of a set of candidate chronicles initializes with a set of chronicles that were proved to be frequent and it uses the constraint database to explore the chronicle space (Cram et al. (2012)).

- The set of candidates initiates with the set of tree roots
- Use the operator "add ε ". This operator, checks at the constraint graphs in order to find the restrictions of ε with all elements of E .
- Determine the minimal number of occurrences of the candidate in \mathbb{S}

The details of the algorithm *HDCAM* can be found in (Subias et al. (2014)).

3.2 Improving restrictiveness/conservatism

3.2.1. *Integration of process knowledge* Expert knowledge can be represented by *temporal runs* that express a known time constraint between two event type dates. These temporal runs are gathered in an expert data base \mathcal{D}_e . To integrate this knowledge, Phase 2 of *HCDAM* is modified. One first checks the existence of a temporal run TR_{ij} for each pair of event types (e_i, e_j) . Temporal run, which replaces the tree root of this pair of event types. The effect of the integration of temporal runs corresponds to focus the learning process and produce less conservative chronicles; it means that the number of chronicles that represents a specific scenario could be reduced using the expertise knowledge.

Definition 6: A temporal run is defined as a partial order of time points with time restrictions between each pair. For the pair of event types (e_i, e_j) , a temporal run is defined as $TR_{ij} = e_i[t^-, t^+]e_j$

Example of the "charge oven" activity: the results of learning obtained without the inclusion of temporal runs and with the inclusion of *temporal runs* are given in a simple example of activity consisting in a charging an oven as represented in Figure. 1. The event types are given by $E = \{a, b, c, d\}$, where a (b) is the event of detecting product a (b) entering the oven, c is the event corresponding to putting the heaters on, and d is the event of setting the heaters to high temperature. The event sequences that express normal startup of this process are:

$$S_1 = \{(a, 2), (b, 4), (a, 5), (c, 7), (d, 11)\}$$

$$S_2 = \{(a, 2), (b, 3), (a, 4), (c, 7), (d, 10)\}$$

$$S_3 = \{(a, 2), (b, 3), (a, 5), (c, 8), (d, 11)\}$$

The temporal runs that indicate the expertise knowledge are $TR_{ab} = a[-2, 2]b$ and $TR_{cd} = c[2, 6]d$. Using the

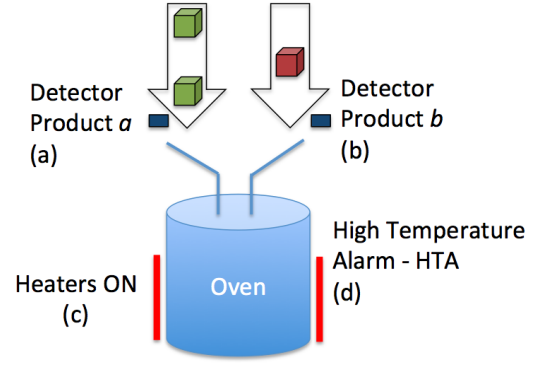

Fig. 1. Example of the "charge oven" activity

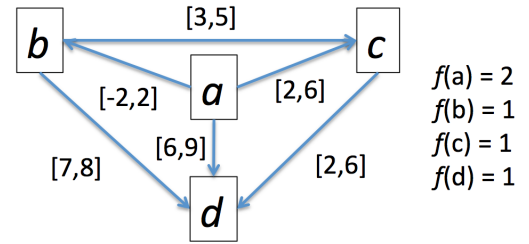

Fig. 2. Unique chronicle of the Charge oven system

algorithm *HCDAM*, the results obtained without including *temporal runs* provide 8 chronicles for a frequency 1. Using the extended version of the algorithm *HCDAM*, the results including *temporal runs* provide 4 chronicles reducing the number of chronicles by 50%.

3.2.2. *Integration of event information* Another type of expert knowledge that is often available is the occurrence frequency $f_{(e_i)}$ of a single event e_i . This information is not taken into account in *HDCAM*. Nevertheless it can be very useful to reduce the number of learned chronicles.

With the event Φ we can to obtain the occurrence frequency of each event type that occurs in S_k . This occurrence frequency permits improved the restrictiveness in the system of chronicles; for example, in a scenario represented by 7 chronicles of frequency 1 and 3 chronicles of frequency 2, the use of the event Φ enables to analyze the system with only one unique chronicle, not 10.

Definition 7: We define the event Φ as the initial event in all the event sequences \mathbb{S} such that the occurrence frequency $f_{(e_i)}$ for each event type e_i in the sequence S_k is determined from this event Φ .

Assuming the above example, we use the integration of event information for structure an unique chronicle reducing the number of chronicles in 90% see Figure. 2. In this chronicle, the concept of frequency is assumed as the occurrence frequency for each event type in a sequence, not as the occurrence frequency of a pair of events.

4. CASE STUDY - VACUUM OVEN

This section presents a case study from the Cartagena Refinery in Colombia. Our proposal aims at helping the operator to recognize specific operation (i.e normal and/or faulty operation) during the startup and shutdown stages

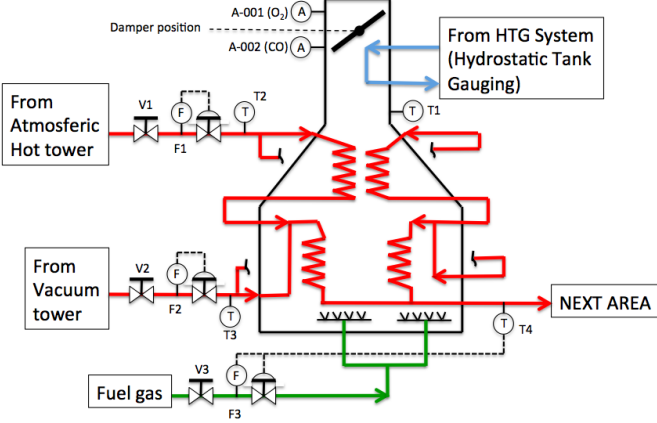

Fig. 3. Vacuum oven

of the vacuum oven unit described Figure 3. This section illustrates then the learning of the chronicle base that will be considered by a recognition system to recognize these normal or faulty situations when they occur, and in the next subsections the CBAM methodology is applied with its three steps: 1. *Event type identification*, 2. *Learning event sequences generation* and 3. *Construction of the chronicle database*, Vasquez et al. (2015), Vasquez et al. (2016).

4.1 Event type identification

The set of event types E considered in the chronicles is defined by $E = \Sigma \cup \Sigma^c$ where:

- Σ is the set of procedural actions performed during standard operating procedures
- Σ^c is the set of event types associated to the behavior of the continuous variables .

Procedural actions concern mainly the valves of the oven and $\Sigma = \{V1, V2, V3, v1, v2, v3, M2A\}$. where $V1$ (resp. $V2, V3$) denotes the switch of the valve $V1$ (resp. $V2, V3$) from closed to opened. $v1$ (resp $v2, v3$) the switch of the valve $V1$ (resp. $V2, V3$) from opened to closed. The event $M2A$ corresponds to the change from *manual* to *automatic* operating, closing the control loops. In the reminder we assume that this event is the only unobservable event of the system i.e. $\Sigma_{uo} = \{M2A\}$.

Continuous variables are associated to the different flows ($F1, F2, F3$) and different temperatures ($T1, T2, T3$ and $T4$) (see Figure 3). For each evolution of a continuous variable (obtained by simulation) upper and lower bounds are defined from experience feedback. Then the continuous values of the variable are mapped to ranges defined by these limits. We propose to define three ranges: *High* when the value of the continuous variable is higher than the upper bound, *Medium* when the value is between the upper and lower bounds, and *Low* when the value is under the lower limit bound. Form this qualitative abstraction of the continuous variable evolution we consider that an event is generated each time a transition between qualitative domains (i.e ranges) occurs. So, for a continuous variable noted v_i four event types can be considered: L_{v_i} (resp. l_{v_i}) for a transition from the range L to the range M (resp. M to L). H_{v_i} (resp h_{v_i}) for a transition from the range M to

the range H (resp. H to M) (Vasquez et al. (2016)). For the vacuum oven the set of event types associated to the behavior of the continuous variables is then defined by:

$$\Sigma^c = \begin{cases} L_{F1}, l_{F1}, H_{F1}, h_{F1}, L_{F2}, l_{F2}, H_{F2}, h_{F2}, L_{F3}, \\ l_{F3}, H_{F3}, h_{F3}, L_{T1}, l_{T1}, H_{T1}, h_{T1}, L_{T2}, l_{T2}, \\ H_{T2}, h_{T2}, L_{T3}, l_{T3}, H_{T3}, h_{T3}, L_{T4}, l_{T4}, H_{T4}, \\ h_{T4} \end{cases} \quad (1)$$

4.2 Learning event sequences generation

The learning event sequences are generated according to the behavior of the system in a given scenario (scenario of normal operating, faulty scenario with a fault on valve, etc...). In this section we consider a scenario of normal behavior during the start up of the oven. By simulation we have obtained three different event sequences (S_1, S_2 and S_3) all of them associated with the same scenario. Figure 4 shows one simulation of the scenario leading to the generation of the sequence S_1 given by:

$$S_1 = \langle (V3, 1), (L_{T1}, 3), (L_{F3}, 5), (V1, 6), (L_{T4}, 7), (L_{F1}, 8), (H_{F1}, 12), (v1, 13), (V2, 14), (H_{T1}, 15), (h_{F1}, 16), (L_{F2}, 17), (H_{T4}, 19), (H_{F2}, 22), (l_{F1}, 24), (h_{T1}, 25), (h_{T4}, 26), (h_{F2}, 27), (V1, 42), (L_{F1}, 45) \rangle$$

The two others sequences S_2 and S_3 are identical to S_1 in term of sequence of event types but differ to S_1 in term of event occurrence dates.

$$S_2 = \langle (V3, 1), (L_{T1}, 7), (L_{F3}, 13), (V1, 18), (L_{T4}, 21), (L_{F1}, 24), (H_{F1}, 32), (v1, 35), (V2, 37), (H_{T1}, 40), (h_{F1}, 45), (L_{F2}, 48), (H_{T4}, 54), (H_{F2}, 61), (l_{F1}, 65), (h_{T1}, 68), (h_{T4}, 72), (h_{F2}, 76), (V1, 96), (L_{F1}, 101) \rangle$$

$$S_3 = \langle (V3, 2), (L_{T1}, 6), (L_{F3}, 9), (V1, 12), (L_{T4}, 14), (L_{F1}, 16), (H_{F1}, 22), (v1, 24), (V2, 25), (H_{T1}, 27), (h_{F1}, 30), (L_{F2}, 32), (H_{T4}, 36), (H_{F2}, 41), (l_{F1}, 43), (h_{T1}, 45), (h_{T4}, 48), (h_{F2}, 50), (V1, 68), (L_{F1}, 71) \rangle$$

This scenario can be interpreted from the standard procedure. For the startup stage, the initial conditions are that the oven (Ov) is empty and the valves $V1, V2$ and $V3$ are closed. In this situation, the values for all the continuous variables are below its low limits ($F1, F2, F3, T1, T2, T3, T4$). Then the scenario starts with the opening of the valve $V3$ that is to say the occurrence of an event of type $V3$. After this event type occurrence, the system is in a mode of operation where only the valves $V1$ and $V2$ are closed. The variable $T1$ increases and an event of type L_{T1} must occur indicating that the internal oven temperature has passed the limit of low. Then the flow of the fuel gas reaches its low limit and an event of type L_{F3} occurs. So, the ordered sequence of event types that has occurred is $V3, L_{T1}, L_{F3}$. Passing the low limit of $F3$ is the condition for continuing the procedure by the action *Open V1* ($V1$). When the operator opens the valve $V1$, the system evolves to a mode of operation where the internal flow in the vacuum oven starts. In this situation, the flow $F1$ and the outflow temperature $T4$ increase (event of type L_{T4} followed by an event of type L_{F1}). The next event that occurs is of type H_{F1} indicating that the flow $F1$ has passed its high level. At

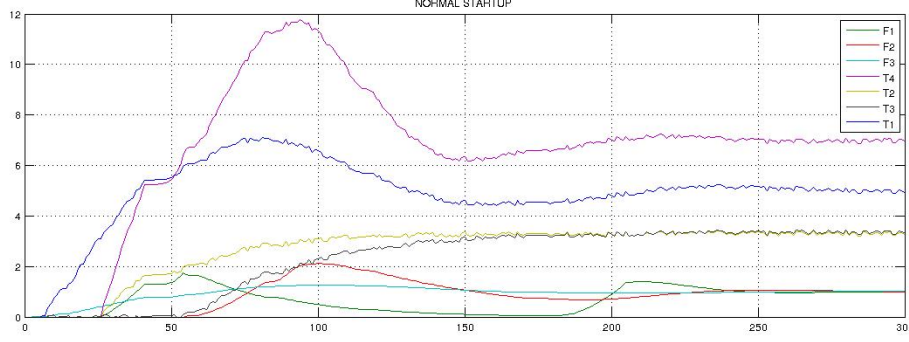

Fig. 4. Simulation of a normal startup (normalized values)

this stage, the ordered sequence of event types is given by: $V3, L_{T1}, L_{F3}, V1, L_{T4}, L_{F1}, H_{F1}$. The next procedural action is the closing of the valve **V1** ($v1$) followed by the opening of the valve **V2** ($V2$). Then, the high limit of the temperature $T1$ is reached and an event of type H_{T1} occurs. The flow $F1$ decreases from its high limit (event type h_{F1}). An event of type L_{F2} occurs because the flow in **V2** increases. The high limit in the temperature $T4$ induced and event of type (H_{T4}). Following up with the procedure, due to the high limit of $F2$ an event of type H_{F2} . At this time point, the ordered sequence of event types that has occurred is $V3, L_{T1}, L_{F3}, V1, L_{T4}, L_{F1}, H_{F1}, v1, V2, H_{T1}, h_{F1}, L_{F2}, H_{T4}, H_{F2}$. In this situation, an unobservable event of type $M2A$ occurs and the control loops are closed, carrying the system to a steady state. Note that in this study, we assume that the control loops are closed immediately after an event of type H_{F2} . Then, $F1, T1$ and $T4$ decrease (event types l_{F1}, h_{T1} and h_{T4}). Finally, the sequence ends by an event of type h_{F2} and by the opening of the valve **V1** so that the last event that occurs in this normal startup is of type L_{F1} .

4.3 Construction of the chronicle database

A complex process (Pr) such as the Cartagena Refinery is composed of $n \in N$ different units or areas $Pr = \{Ar_1, Ar_2, \dots, Ar_n\}$ where each area $Ar_m, m = 1, \dots, n$ has $K \in N$ operational modes (e.g. startup, shutdown ..) noted $O_i, i = 1, \dots, K$. The process behavior in each operating mode can be either normal or faulty. We define the set of failure labels $\Delta_f = f_1, f_2, \dots, f_r$ and the complete set of possible labels is $\Delta = N \cup \Delta_f$, here N means normal.

To monitor the process and to recognize the different situations (normal or faulty) of the operational modes, we propose to build a chronicle base for each area. For a given area, a learned chronicle C_{ij}^m is associated to each couple (O_i, l_j) where $l_j \in \Delta$:

$$CAr_m = \begin{matrix} O_1 \\ O_2 \\ \dots \\ O_k \end{matrix} \begin{bmatrix} N & f_1 & f_2 & \dots & f_r \\ C_{10}^m & C_{11}^m & C_{12}^m & \dots & C_{1r}^m \\ C_{20}^m & C_{21}^m & C_{22}^m & \dots & C_{2r}^m \\ \dots & \dots & \dots & \dots & \dots \\ C_{k0}^m & C_{k1}^m & C_{k2}^m & \dots & C_{kr}^m \end{bmatrix} \quad (2)$$

When $l_j = N$, the chronicle is a model of the normal behavior of the considered system, otherwise ($l_j = f_i$) the

chronicle is a model of the behavior of the system under the occurrence of the fault f_i .

For the vacuum oven we have considered a normal startup, a normal shutdown and several faulty cases. For instance, a startup stage during which a fault occurs on the control valve **V3**. We present in this section only the chronicle C_{10}^2 learned from the input sequences S_1, S_2 and S_3 capturing a normal startup operating mode of the vacuum oven (area number 2 of the Cartagena Refinery).

In this case of normal startup stage, expert knowledge is available and integrated in our proposal by three *temporal runs*:

$TR_{V3, L_{F3}} = V3[6, 8]L_{F3}$, this temporal run expresses that the lower limit of the flow in $F3$ arrives between 6 and 8 time units after that the valve **V3** is opened.

$TR_{V1, L_{F1}} = V1[-76, 82]L_{F1}$, this temporal run indicates that the lower limit of the flow in $F1$ can occur 76 time units before that the valve **V1** is opened or 82 time units after that.

$TR_{L_{F2}, V2} = L_{F2}[2, 8]V2$, this temporal run indicates that the valve **V2** is opened between 2 and 8 time units after that the lower limit of the flow in $F2$ happens.

The output of the extended *HCDAM* in this case is a chronicle that represents the behavior of the system taking as reference the representative event sequences obtained by simulation and the *temporal runs* obtained from the expertise knowledge. The directed graph associated to the chronicle C_{10}^2 is given in Figure 5. As we can see in the chronicle resulted C_{10}^2 , this chronicle expresses the temporal pattern for a normal start up of this system. Although the three representative event sequences in this scenario are similar, this temporal pattern can represent other cases where the order of the event types could be different between the learning event sequences. The frequency of occurrence of the event types $V1$ and L_{F1} are $f_{V1}=2, f_{L_{F1}}=2$ and for the others event types it is 1. With this information and the use of *temporal runs*, the resulted chronicle is only one for this scenario.

5. CONCLUSION AND FUTURE WORK

A new methodology for an alarm management based on a diagnosis process has been proposed. The proposal is based on a hybrid causal model of the system and a chronicle based approach for diagnosis. An illustrative example of

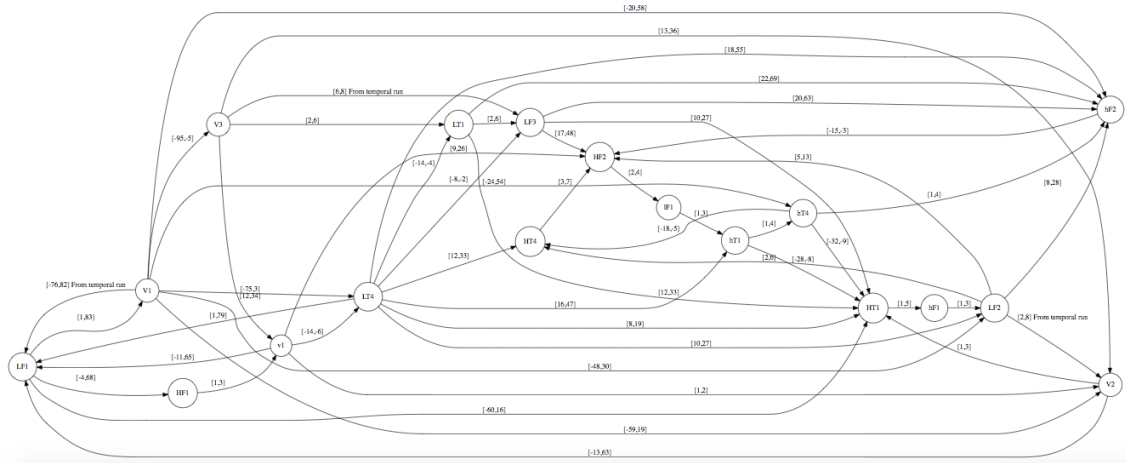

Fig. 5. Directed graph (\mathcal{G}) of the chronicle C_{10}^2

the vacuum oven has been considered to introduce the main concepts of the approach. The algorithm *HCDAM* is a tool for the automatic generation of the chronicles from the representative event sequences and partial temporal runs. Transposing this methodology to large-scale systems would benefit from a decentralized approach in which local chronicles would be learned and then integrated thanks to shared events.

Future work

The following work will be related to the testing and validation of the model of chronicles. A new approach to carry into account negative examples and forgetting capabilities in the chronicle learning algorithm will be proposed.

ACKNOWLEDGEMENTS

The ECOPETROL - ICP engineers Carlos Agudelo, Jorge Prada, Francisco Cala and Gladys Valderrama help us to develop and validate the simulations.

REFERENCES

Basseville, M. (2001). On fault detectability and isolability. *European journal of control*, 7(6):625-637.

Cram, D., Mathern, B., and Mille, A. (2012). A complete chronicle discovery approach: application to activity analysis. *Expert Systems*, 29(4):321 to 346.

Dechter, R., Meiri, I., and Pearl, J. (1991). Temporal constraint networks. *Artificial intelligence*, 49(1):61-95.

Dousson, C. (1996). Alarm driven supervision for telecommunication network: On-line chronicle recognition. In *Annales Des Télécommunications, volume 51, pages 501-508*.

Dousson, C. (2002). Extending and unifying chronicle representation with event counters. In *Proc. of the 15th ECAI, pages 257-261*. IOS Press.

Ghallab, M. (1996). On chronicles : Representation, on-line recognition and learning. In *Proc. of the 5th International Conference on Principles of Knowledge Representation and Reasoning (KR-96)*, 597-606.

Pencolé, Y. (2004). Diagnosability analysis of distributed discrete event systems. *ECAI04 : Proceedings of Euro-*

pean Conference on Artificial Intelligence, pages 43 to 47.

Stanley, G. and Vaidhyanathan, R. (1998). Generic fault propagation modeling approach to on-line diagnosis and event correlation. *3rd IFAC Workshop on On-Line Fault Detection and Supervision in the Chemical Process Industries*, Solaize, France., June 4-5, 1998.

Subias, A., Travé-Massuyès, L., and LeCorronc, E. (2014). Learning chronicles signing multiple scenario instances. *IFAC World Congress, Le Cap, South Africa, 26-29 August*.

Vasquez, J., Travé-Massuyès, L., Subias, A., Jimenez, F., and Agudelo, C. (2015). Chronicle based alarm management in startup and shutdown stages. *International Workshop on Principles of Diagnosis (DX-2015), Paris*.

Vasquez, J., Travé-Massuyès, L., Subias, A., Jimenez, F., and Agudelo, C. (2016). Alarm management based on diagnosis. *4th IFAC International Conference on Intelligent Control and Automation Sciences (ICONS 2016), Reims*.