



**HAL**  
open science

## Polyethylene Outgassing Study for MEMS Nuclear Radiation Sensor

Dheeraj Kumar, Julien Philippe, Samuel Charlot, Sandrine Assié-Souleille, Aurélie Lecestre, André Ferrand, Hervé Aubert, Patrick Pons

► **To cite this version:**

Dheeraj Kumar, Julien Philippe, Samuel Charlot, Sandrine Assié-Souleille, Aurélie Lecestre, et al.. Polyethylene Outgassing Study for MEMS Nuclear Radiation Sensor. Eurosensors 2018, Sep 2018, Graz, Austria. pp.9 - 12. hal-01852434

**HAL Id: hal-01852434**

**<https://laas.hal.science/hal-01852434v1>**

Submitted on 1 Aug 2018

**HAL** is a multi-disciplinary open access archive for the deposit and dissemination of scientific research documents, whether they are published or not. The documents may come from teaching and research institutions in France or abroad, or from public or private research centers.

L'archive ouverte pluridisciplinaire **HAL**, est destinée au dépôt et à la diffusion de documents scientifiques de niveau recherche, publiés ou non, émanant des établissements d'enseignement et de recherche français ou étrangers, des laboratoires publics ou privés.

# Polyethylene Outgassing Study for MEMS Nuclear Radiation Sensor

D. Kumar<sup>1,2,†</sup>, J. Philippe<sup>2</sup>, S. Charlot<sup>2</sup>, S. Assié<sup>2</sup>, A. Lecestre<sup>2</sup>, A. Ferrand<sup>1,2</sup>, H. Aubert<sup>2</sup> and P. Pons<sup>2\*</sup>

<sup>1</sup> ICA, Université de Toulouse, Toulouse, France

<sup>2</sup> LAAS-CNRS, Université de Toulouse, CNRS, INP, Toulouse, France

Emails: dkumar@laas.fr, jphilipp@laas.fr, scharlot@laas.fr, sassie@laas.fr, alecestre@laas.fr, andre.ferrand@insa-toulouse.fr, aubert@laas.fr

\* Correspondence: ppons@laas.fr, 33-5-61-33-64-63

† Presented at the Eurosensors 2018 Conference, Graz, Austria, 9–12 September 2018.

Published: date (leave it empty)

**Abstract:** In this paper, the out-gassing from PolyEthylene (PE) film is studied under nuclear irradiation for the design and fabrication of passive MEMS dosimeters. The fabrication of sensor needs high temperature process that leads to specific constraints on the PE film. Radiation chemical yield of hydrogen production ( $G_{H_2}$ ) from PE under gamma irradiation is verified by mass spectroscopy after temperature annealing in vacuum up to 400°C. Prototypes are fabricated to validate the fabrication of the sensor and then irradiated with high energy gamma radiation (with dose of 20 kGy). Measurements of membrane deflections after irradiation validate the  $G_{H_2}$  factor, showing low pollution level of PE during sensor fabrication.

**Keywords:** polyethylene; nuclear radiation sensor; MEMS dosimeters; hydrogen outgassing

---

## 1. Introduction

Wireless passive (battery-less) and chip-less (without electronic circuits) sensors present interesting solution for harsh environment applications. In the case of nuclear radiation measurement, such solutions allow real time dose monitoring by remotely interrogating nuclear radiation sensors from radar reader [1].

The operating principle of the sensor is the following: when PolyEthylene (PE) placed inside a hermetic sealed cavity is subjected to nuclear irradiation, an outgassing (mainly of  $H_2$  molecules) occurs and generates a pressure on a highly resistive silicon membrane. This lead to the membrane deflection, which modify the resonant frequency of a planar microwave resonator placed just below the membrane. From the measurement of the frequency shift, the nuclear radiation dose is derived.

In our previous design (see Figure 1), a double Si/Glass stack was used for the sensor fabrication and leads to a complex technological process and non-sealed cavity for the resonator. The PE was obtained from peeling small ball and the Si/Glass2 bonding was performed under  $N_2$  using a non-collective process Moreover, the sensor sensitivity varied significantly from one sensor to another and was about 20 times higher than the simulation results [2]. The possible reason could be the pollution of PE during sensor fabrication leading to the undesirable out-gassing after irradiation. Consequently, in order to control these additional out-gassing of PE, we report here a simple, more reliable and collective technological fabrication process for passive MEMS dosimeters with a new design (see Figure 2). The process uses a simple Si/Glass stack where the calibrated 200 $\mu$ m thick High Density PolyEthylene (HDPE) film and the resonator are sealed inside the same cavity under vacuum. Moreover, the millimeter-wave excitation of the resonator is performed by using a small radiating aperture [1].

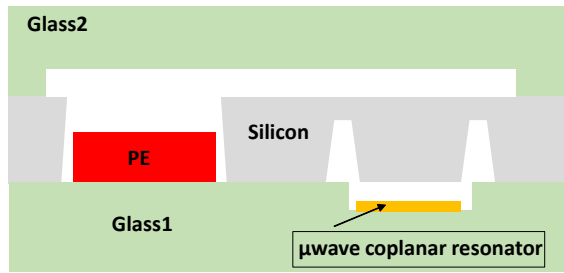

Figure 1. Previous dosimeter design

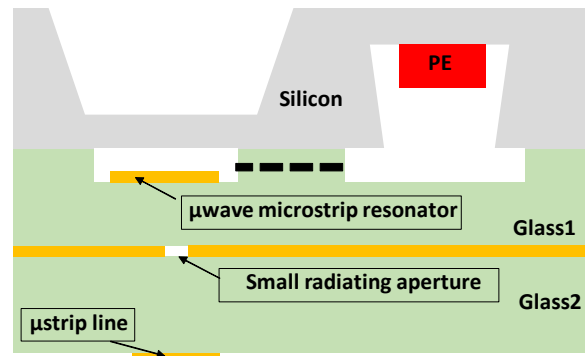

Figure 2. New dosimeter design

## 2. Materials and Methods

Prototypes were designed to measure radiation chemical yield of hydrogen production ( $G_{H_2}$ ) from sensing devices fabricated with technological process similar to that used for the final sensors (see Figure 3). The HDPE cavity (5mm diameter and 290 $\mu$ m depth) is etched inside a low resistivity 400 $\mu$ m thick SOI wafer. The  $H_2$  out-gassing will provide the deflection of the small silicon membrane (550 $\mu$ m diameter and 5 $\mu$ m thick) that will be monitored with optical profiler.

For  $G_{H_2} = 4.10^{-7}$  mol/J, the pressure  $P_g$  generated by the PE is given by equation 1 [2], where  $V_{PE}$  and  $V_g$  denote respectively the PE volume and the volume of gas expansion:

$$P_g[\text{Bar}] = 9.5 \cdot 10^{-3} \frac{V_{PE} [\text{mm}^3]}{V_g [\text{mm}^3]} \cong 10^{-2} \frac{V_{PE} [\text{mm}^3]}{V_g [\text{mm}^3]} / \text{kGy} \quad (1)$$

With dimensions given in the Figure 3,  $P_g \cong 0.045$  bar/10kGy which leads a membrane deflection sensitivity of 0.23 $\mu$ m/10kGy.

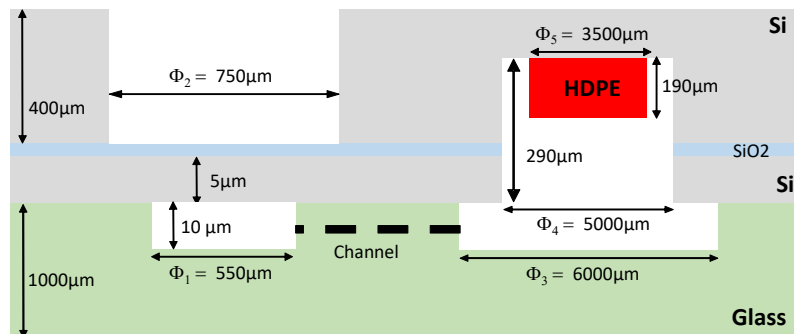

Figure 3. Cross section of the prototype for the measurement of  $G_{H_2}$

## 3. Results and discussions

### 3.1. PE properties

One of the major issue during the technological fabrication of sensors is the use of high temperature silicon/glass anodic bonding that may degrade the  $H_2$  out-gassing capabilities of HDPE. The thermo-gravimetric analysis performed under Helium (He) atmosphere shows that the degradation of HDPE occurs only above 400 $^{\circ}$ C (see Figure 4). To provide a security margin, the silicon/glass temperature bonding is then performed at 350 $^{\circ}$ C.

HDPE samples are annealed in vacuum at 350 $^{\circ}$ C and then placed in a sealed glass tube under He atmosphere. After irradiation to gamma rays ( $^{137}\text{Cs}$  661.7 keV, dose rate 0.3kGy/h, dose 24kGy), the gas composition analysis is finally performed using a quantitative gas mass spectrometer. It shows that  $H_2$  production is not affected by high temperature process ( $G_{H_2} \cong 4 \cdot 10^{-7}$  mol / J) [3].

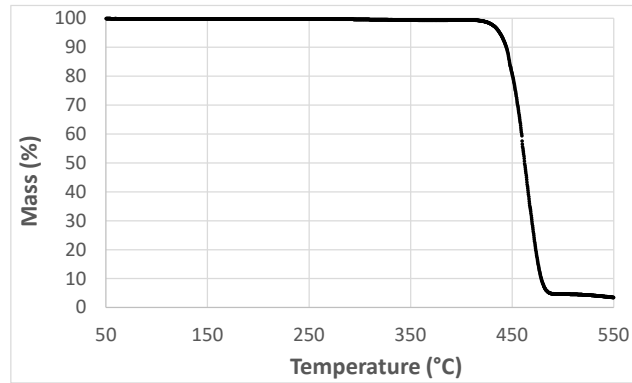

Figure 4. Evolution of PE mass versus temperature

3.2. Prototypes fabrication and characterization before irradiation

For silicon wafer fabrication, the two main steps were: (1) the 5µm thick membrane release and (2) the HDPE cavity fabrication with deep reactive ionic etching using 40µm thick photoresist mask. For the glass wafer, the 10µm depth cavity were obtained from etching in hydrofluorydric bath using Chromium/Gold mask.

After 2 minutes annealing at 200°C under vacuum, 200µm HDPE film was cut using a stamping pliers and the 3.5mm diameter samples were placed inside the silicon cavity. Silicon and glass wafer were aligned in AML bonder, heated at 350°C under vacuum during 30min and then bonded at 600V. Prototypes were fabricated using this technological process (see Figure 5). Before silicon/glass bonding, the membrane deflection is small ( $\cong 0.2\mu\text{m}$ ) and after bonding, the deflection is found to range from 5.1µm to 5.4µm for atmospheric pressure applied on the top of the membrane (see Figure 6). This experimental result is close to the expected value with vacuum inside the cavity (simulated sensitivity was of 5µm/bar). After two weeks, the membrane deflection remains unchanged.

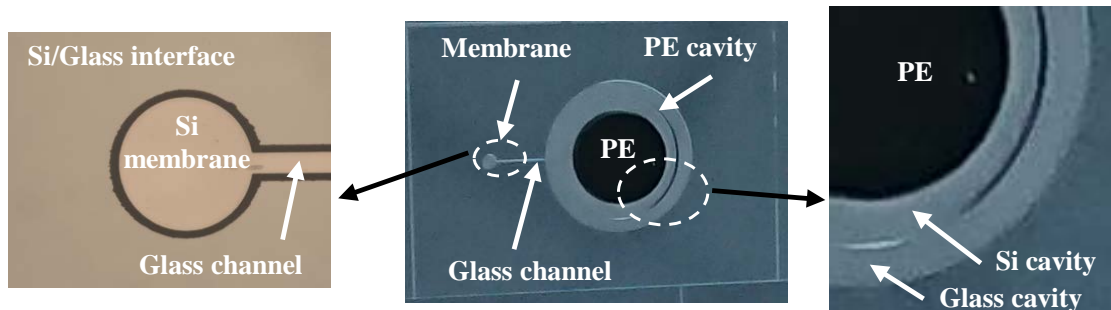

Figure 5. Bottom views of fabricated prototypes

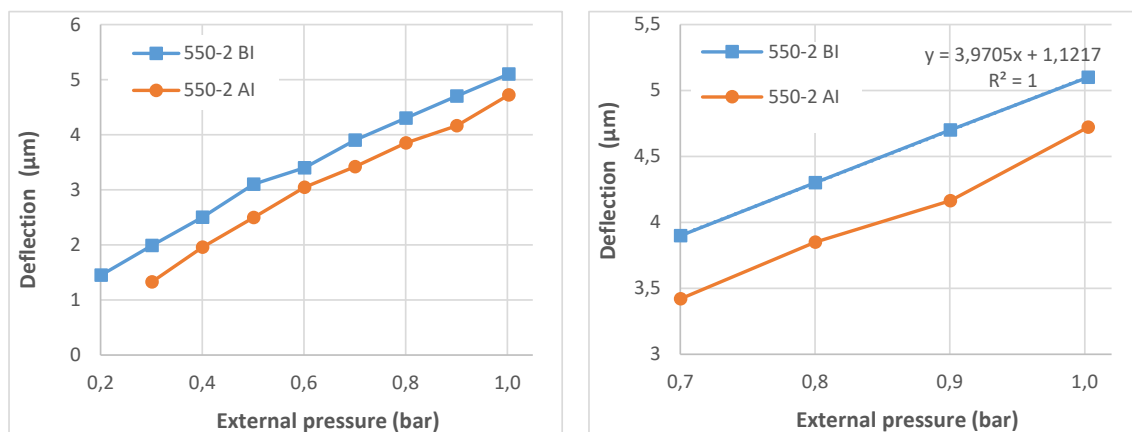

Figure 6. Membrane deflection versus external pressure applied on the top of the membrane (BI : Before Irradiation, AI : After Irradiation)

As displayed in Figure 6, the membrane sensitivity to pressure variation was also calibrated under pressure between 0.2 bar and 1 bar. For pressure between 0.8 bar and 1 bar, the sensitivity  $S$  is around 4  $\mu\text{m}/\text{bar}$ .

### 3.3. Prototypes characterization after irradiation

The prototypes are irradiated to gamma rays ( $^{137}\text{Cs}$  661.7 keV, dose rate 0.3kGy/h, dose 20kGy). The membrane sensitivity to pressure was also calibrated 3 weeks after irradiation and we checked that no significant change occurred after irradiation (see Figure 6). For atmospheric pressure, the membrane deflection is reduced by 0.4 $\mu\text{m}$ . The pressure  $P_g$  generated inside the HDPE cavity after this irradiation can be then derived from equation (2) :

$$P_g = \Delta P_o - (\Delta D/S) \quad (2)$$

where  $\Delta P_o$  denote the atmospheric pressure variation between two measurements of membrane deflection,  $\Delta D$  is the variation of the membrane deflection related to irradiation dose and  $S$  designates the membrane sensitivity around 1 bar derived from Figure 6. The pressure  $P_g$  is then found to be of 0.05 bar/10kGy and is close to the expected value (simulation results predict a pressure of 0.045 bar/10kGy).

After two weeks, the membrane deflection remains unchanged and consequently, we concluded that a good  $\text{H}_2$  tightness was achieved.

## 4. Conclusions

Prototypes based on silicon membrane were designed and fabricated to validate the fabrication process of a passive MEMS dosimeter. After irradiation to gamma rays (20kGy), membrane deflection analysis shows that the radiation chemical yield of hydrogen production ( $G_{\text{H}_2}$ ) from HDPE is close to simulation results. So few undesirable out-gassing from polyethylene occurs during prototype irradiation, validating the fabrication process with low level of HDPE pollution.

**Acknowledgments:** This work was partially funded by CARANUC project (Occitanie Region, France and Europe) and EDF (Electricité de France). This work was partly supported by LAAS-CNRS micro and nanotechnologies platform, members of the French RENATECH network.

**Conflicts of Interest:** The authors declare no conflict of interest. The founding sponsors had no role in the design of the study; in the collection, analyses, or interpretation of data; in the writing of the manuscript, and in the decision to publish the results.

## References

1. C. Arenas et al., Wireless and Passive Nuclear Radiation Sensors, European Microwave Week, 8-13 Oct 2017, Nuremberg, Germany
2. I. Augustyniak et al., Micromechanical high-doses radiation sensor with bossed membrane and interferometry optical detection, Sensor and Actuator, Volume 232, August 2015, Pages 353–358
3. T. Seguchi, Hydrogen yield from polyethylene by radiolysis and the application to dosimeter, Asian-Pacific Symposium on Radiation Chemistry; Shanghai (China); 17-21 Sep 2006

