



HAL
open science

Enabling Internet of Everything Everywhere: LPWAN with satellite backhaul

Maria Rita Palattella, Nicola Accettura

► **To cite this version:**

Maria Rita Palattella, Nicola Accettura. Enabling Internet of Everything Everywhere: LPWAN with satellite backhaul. 2018 Global Information Infrastructure and Networking Symposium (GIIS), Oct 2018, Thessaloniki, Greece. pp.1-5, 10.1109/GIIS.2018.8635663 . hal-02063876

HAL Id: hal-02063876

<https://laas.hal.science/hal-02063876>

Submitted on 11 Mar 2019

HAL is a multi-disciplinary open access archive for the deposit and dissemination of scientific research documents, whether they are published or not. The documents may come from teaching and research institutions in France or abroad, or from public or private research centers.

L'archive ouverte pluridisciplinaire **HAL**, est destinée au dépôt et à la diffusion de documents scientifiques de niveau recherche, publiés ou non, émanant des établissements d'enseignement et de recherche français ou étrangers, des laboratoires publics ou privés.

Enabling Internet of Everything Everywhere: LPWAN with satellite backhaul

Maria Rita Palattella

Luxembourg Institute of Science and Technology, LIST
Esch-sur-Alzette, Luxembourg
mariarita.palattella@list.lu

Nicola Accettura

LAAS-CNRS, Université de Toulouse, CNRS
Toulouse, France
nicola.accettura@laas.fr

Abstract—One of the basic requirements of the Internet of Things (IoT) is that all the devices are connected wherever they happen to be. While Wi-Fi, Bluetooth, 4G cellular networks are able to support many IoT applications, they cannot provide an ubiquitous and seamless coverage as satellites. Connecting terrestrial IoT network segments directly to IoT service back ends via satellite broadband is becoming a new business focus, creating opportunities for notable use of hybrid Low Power Wide Area Network (LPWAN) to satellite gateways. In the present work we analyze the potential of satellite for the IoT. We review the present-day initiatives from Satellite and Telco operators to deploy satellite-enabled LPWANs. Last but not least, we illustrate the technical challenges to be faced for interconnecting satellite and LoRaWAN networks, which call for further research investigation.

Index Terms—Internet of Things, IoT, Low Power Wide Area, LPWAN, LoRaWAN, satellite, backhaul

I. INTRODUCTION

Internet of Things (IoT) applications are bringing fundamental changes in our life, and in all sectors of activity, representing an engine for innovation, economic growth, and social progress. A large variety of communication technologies has gradually emerged, reflecting a large diversity of application domains and communication requirements [1]. While all of them are able to support many IoT applications, none can reach all the possible markets and customers.

For several IoT applications, long range, low cost, and low power consumption are the main connectivity constraints to meet, and this makes many network technologies impractical. For instance, Bluetooth and Wi-Fi offer low power consumption and provide reliable connectivity over short distance, at a low cost; on the contrary 4G (LTE, NB-IoT, etc.) and upcoming 5G technologies offer connectivity over longer distances, but with high cost and considerable power consumption.

In the last couple of years, Low Power Wide Area Network (LPWAN) technology came out as a better choice for enabling longer range connections, at greater cost and power efficiencies. LPWANs allow low power devices to directly interact with some gateways through long range transmissions [2]. LPWANs are currently available in many different proprietary solutions (SigFox and LoRa, among many others). For example, in a LoRa network a central server coordinates several gateways. Each gateway relays traffic generated by low power end-devices to the application server over reliable links.

LPWANs are suitable for IoT applications with low data-rate, not sensitive to packet loss, and transmission delay. Thus, environmental monitoring (e.g. water, snow level outdoors), precision agriculture (e.g. soil moisture, crop growth), civil engineering (i.e., oil and gas mining), transportation are among its main application domains [3]. Some of these use cases may be deployed in remote, sparsely populated areas that do not have mobile terrestrial coverage, or other forms of connectivity. In this context, the satellite technology comes into play, as a key enabler to transform IoT connectivity across industries and geographical borders [4], [5], and allow *global IoT coverage*, namely *Internet of Everything Everywhere* (IoEE). The potential innovation that would result in integrating satellite segments within the backhaul network of LPWAN-based IoT applications has been recognized in the last years by several satellite operators, and IoT companies. Inmarsat, a leading provider of global mobile satellite communications service, joined the LoRa Alliance in 2016 to provide LoRa networks with satellite connectivity [6]. After one year, Inmarsat together with Actility, industry leader in LPWANs, deployed the world's first global IoT network, with LoRaWAN-based connectivity on the ground, and satellite connectivity at the network backbone. The integrated hybrid network has been tested in three application scenarios: asset tracking, agribusiness, oil and gas, deployed in remote regions of Australia and Malaysia. At the European Conference on Precision Agriculture (ECPA2017) Inmarsat demonstrated the use of a geostationary earth orbit (GEO) satellite to enable IoT, by connecting a LoRa gateway to a Broadband Global Area Network (BGAN) terminal, and transmitting data via satellite. Last, but not least, Lacuna Space company, in collaboration with Semtech Corporation (i.e., LoRa's inventor), and with the funding and technical support of the European Space Agency (ESA) is working on the deployment of an end-to-end (e2e) IoT solution with LoRa devices communicating directly with a constellation of low earth orbit (LEO) low-cost cubesats satellites. The data collected from the sensors, is stored by the satellites till they are in visibility with the ground stations. The latter can relay the data over terrestrial networks to any end IoT application. To deploy such scenario, Lacuna Space is working in enabling LoRa low power devices with satellite connectivity, and building LEO satellites with integrated LoRa gateway. The project is ongoing, and first services over the integrated Lacuna

Space networks should be available by September 2018. But a first demonstration was already given in February 2018, at the Things Conference (the leading LoRaWAN developer conference organized by The Things Network) [7].

Clearly, connecting terrestrial IoT network segments directly to IoT service back end via satellite broadband is becoming a new business focus. Besides the new market opportunities, and the additional revenue that the backhaul of LPWANs can bring for satellite operators and IoT services providers, there is need to design technical solutions that allow the smooth integration and interoperability of satellite and terrestrial segments. In this paper we highlight the main issues to overcome, and we define some research directions to further investigate in future work.

II. LPWAN TECHNOLOGIES

One of the basic feature of the IoT is that all devices are connected *wherever* they happen to be. IoT devices are small cheap low power devices, usually equipped with battery, or energy harvesting modules. Given their scarce energy capability, most of the first technologies designed for IoT leveraged on short range communications for the interaction among devices.

To extend the scope of the resulting network to larger deployments, two main architectural approaches were adopted. According to the first approach, several IoT devices can communicate over short links with a single collector device that ties the resulting single-hop network with the Internet [8]. IoT devices can easily optimize their energy consumption by properly duty-cycling their activity. However, the deployment extension is limited by the short transmission range around the collector node. It is possible to achieve a bigger coverage by enabling long range low power backhaul communication between the collector node and some access points to the Internet, thus realizing a cluster-head Wireless Sensor Network (WSN). The alternative approach is enabled when all devices still use short range communications to self-organize through mesh networking into a multi-hop WSN. Such a network is headed at a collector node, that in turn handles a wide deployment, i.e., not limited to the short-range communication distance. Resilience to malfunctioning is ensured by routing protocols through path maintenance over the mesh. This functionality requires some additional storage and computation capabilities on the hardware that makes low power devices less cheap. To further reduce power consumption, it has been proved that synchronization [9] helps in duty cycling the radio activity, thus making batteries last for years.

Recently Low Power Wide Area Networks emerged as a better choice to allow long-distance communication between low power devices and Internet connected applications. LPWANs allow low power devices to directly interact with some gateways through long range transmissions. With respect to cluster-head WSNs, there is no collector node handling low power devices in the close neighborhood and interfacing them with the access point to the Internet. Indeed, each low power device directly communicates with such an access

point. Instead, with respect to multi-hop meshed WSNs, there is no need for sophisticated routing strategies among low power devices: the needed capabilities are limited to handling single-hop communications. Without a strict need of powerful circuitry, it is then possible to deploy more capillary networks of very cheap low power devices [10].

Many LPWAN technologies have been developed in the last years [2], including LoRa, Sigfox, and Narrow Band IoT (NB-IoT) among many others.

Of these, Sigfox [11] is an LPWAN technology that uses an ultra narrow band modulation over unlicensed spectrum to reduce noise and increase the number of supported devices. These advantages are paid in terms of a very low maximum throughput of about 100 bits per second. Furthermore, the communication is mostly directed uplink, i.e., with low power devices sending very small frames to Sigfox gateways. In the latest Sigfox release, there is a minimal support for downlink communications in the order of 4 messages of 8 bytes per day. This asymmetric communication pattern does not permit either real-time pulling of data from sensors or an easy remote configuration of low power devices. It has to be mentioned that the medium access layer of Sigfox is proprietary, hence modifications of the operating conditions are not straightforward.

Like Sigfox, also NB-IoT [12] employs a narrow band modulation. It was conceived within the 3GPP to make evolve current cellular network for supporting IoT applications. Hence, NB-IoT works into the licensed spectrum. Its specification is still evolving, and there is a substantial lack of deployments [2] to test energy efficiency of such technology. As matter of facts, low power devices should first get synchronized to the network before starting data delivery. This feature translates into some waste of energy when traffic is sporadic: low power device have to idle listen for synchronization signals before transmitting each of the sporadic packets they have to deliver through the Internet. In addition, some additional hardware complexity is needed for bounding clock drift that may induce desynchronization: the cost of low power devices is then increased.

LoRa [13], instead, is based on spread spectrum modulations, works in the unlicensed spectrum and provides a configurable tradeoff between energy efficiency and management of traffic burden. This and other features are described in the next subsection.

A. LoRa networks

Semtech Corporation recently introduced the Long Range (LoRa) technology at the physical layer [14]. With the increasing interest to LoRa communications by many industrial partners throughout the world, the LoRa Alliance has been created with the scope of promoting LoRa communications and defining a Medium Access Control (MAC) layer able to manage LoRa Wide Area Networks (LoRaWAN) [13], [15], [16]. Very low power communications are attained through the exploitation of Chirp Spread Spectrum. With such a modulation, a narrow band signal is spread over a wider bandwidth

before being transmitted, and the signal can be correctly decoded at long distance also when severely attenuated below the noise floor.

The LoRa modulation is available with several spreading factors (SFs), i.e., from 7 to 12, to tradeoff between the resulting datarate and the transmission range. Each SF can be employed on different bandwidth sizes (125, 250, and 500 KHz). The combination of SF and bandwidth size identifies a specific datarate. The datarates exploitable throughout the world depend on regional regulation. As an example, in Europe, the ISM band at 863 – 870MHz permits 7 datarates. However, the availability of several datarates is in fact useless in very dense networks as in smart cities, since using just the highest one is the only reliable choice [17].

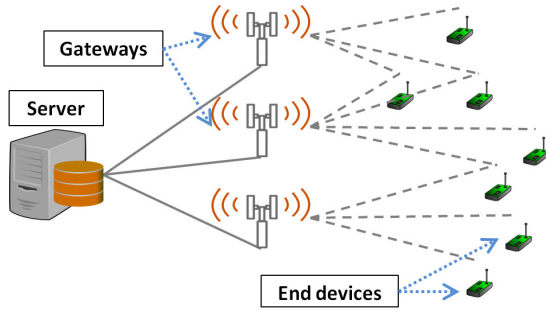

Fig. 1. LoRaWAN architecture

Depending on regional regulations, LoRa operates with all the available datarates on different channels. In Europe, the ISM band 863–870 MHz is policed by the European Telecommunications Standards Institute (ETSI) [18] with duty-cycle limitations specific per sub-band.

Specifically, LoRa devices must implement:

- 3 channels in the 868 – 868.6 MHz sub-band, each with a 125 KHz width. The channels must be respectively centered at 868.1, 868.3, and 868.5 MHz. A 1% duty cycle applies to the whole sub-band.
- 1 communication channel in the 869.4 – 869.65 MHz sub-band with a 1% duty cycle allowance.

From a MAC layer point of view, LoRa networks are organized as pictured in Fig. 1. Low power battery-operated *end-devices* join a LoRaWAN through wireless LoRa links to some *gateways*. Such gateways are coordinated by a *server* through a reliable backhaul network. The server is also in charge of handling the over the air activation of end-devices and roaming operations [16].

In the basic LoRaWAN communication mode, pictured in Fig. 2, when an end-device has got an information to deliver through the LoRaWAN server to some agent in the Internet, it performs the following operations: (i) it checks if it can transmit, according to the duty cycle policy [15], [18]; (ii) if it can transmit, it immediately turns on its radio; (iii) it selects one of the available channels; (iv) it uses that channel to transmit the information encapsulated into a LoRaWAN frame. All LoRaWAN gateways falling into the transmission

range of that end-device capture the signal related to the frame transmission. Some of these gateways detect frame collisions due to simultaneous transmissions originated by concurrent end-devices. At the same time, other gateways correctly decode the frame, extract the included payload, and forward it to the server jointly with the perceived signal strength. Hence, it is up to the server to discard redundant copies of the received frame.

When a frame is sent by an end-device to the server, an acknowledgement (ACK) may be required. In that case, the server instructs a single gateway (among the ones that forwarded a copy of the frame) to acknowledge the correct reception of the frame. In case an information is in the server buffer waiting to be delivered towards the end-device, it is piggybacked to the ACK. In other words, frames can be delivered downlink to an end-device only when it has previously started an uplink communication. Such a communication pattern, called LoRaWAN *Mode A*, is bidirectional, but totally asymmetric. Indeed the round-trip delay is bounded only for uplink communications. As pictured in Fig. 2, an end-device opens a receiving window after a pre-configured time on the same channel used for the uplink transmission (by default this is chosen among the 3 channels available in the 868 – 868.6 MHz sub-band). If the ACK is not received during such window (e.g., this happens if the server has to comply with the duty cycle limitation in the sub-band), a second receiving window is opened using the single channel available in the 869.4 – 869.65 MHz sub-band (which is used only for downlink traffic, since it is policed by a less strict duty cycle limitation).

The LoRaWAN specification provides two enhancements to *Mode A*, respectively named *Mode B* and *Mode C*, to allow interactive downlink communications. These enhancements are paid with additional energy consumption. If *Mode C* is tailored for mains-powered actuators (the radio of end-devices is always on to idle listen to incoming frames) without energy-saving constraints, *Mode B* can be considered as a good candidate for applications requiring totally symmetric

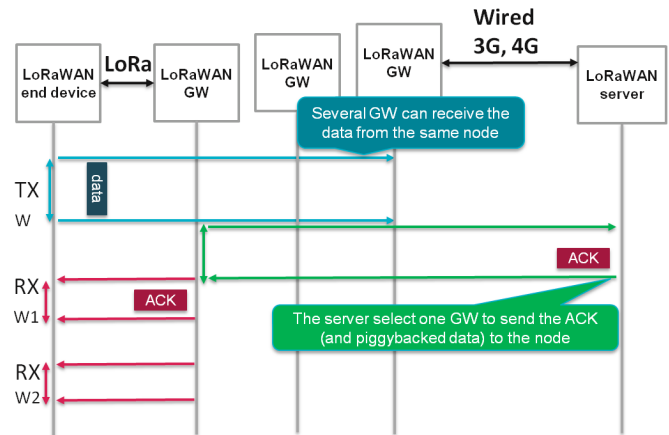

Fig. 2. LoRaWAN Mode A

communications between end-devices and any agent through the Internet. *Mode B*, as sketched in Fig. 3, enables synchronization of end-devices to beacons broadcast by the gateways on the channel in the 869.4 – 869.65 MHz sub-band. Once synchronized, end-devices can schedule periodic *ping slots*, i.e., receiving windows on the same channel used for beacons and for ACK reception in the second receiving window of *Mode A*. Through *ping slots*, the server can directly deliver frames to correspondent end-devices without waiting they start an uplink communication.

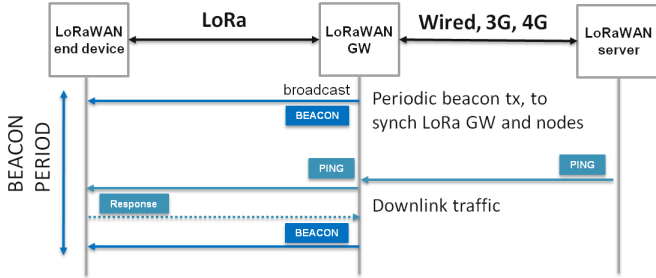

Fig. 3. LoRaWAN Mode B

III. LPWAN WITH SATELLITE BACKHAUL

Integrated satellite-terrestrial networks are emerging as a promising solution to ensure ubiquitous connectivity for many IoT applications deployed in harsh and remote environments. Satellite systems are a cost-effective solution for backhauling and thus complementing terrestrial networks where the latter are not easy to deploy (e.g., in cliff, slopes), or when they get damaged, after natural disasters (such as floods, earthquakes, tornadoes, etc.) [4]. Besides seamless coverage, satellite systems also offer reliability, and support for high data-rate applications, allowing traffic offloading from terrestrial networks. This is appealing given the upcoming deployments of massive IoT applications in the 5G era [19].

While the potential of such hybrid networks are well recognized, a lot of design work is left head to enable interoperability and full integration. A preliminary study on the design of a LEO constellation-based IoT network architecture was conducted in [20]. Authors focused on the NB-IoT technology, and highlighted some of the main issues to face in the system design, such as: interference, synchronization, transmission schemes, security, etc. A different issue was addressed in [21], where an Iridium-LoRaWAN prototype (including a GEO satellite segment) was deployed and used to test data exchange formats for IoT applications running on hybrid networks.

In the present paper we consider LoRaWAN networks backhauled with a satellite system. Two different configurations are possible, depending by the type of access of the LoRaWAN end-devices to the satellite: direct or indirect.

Connecting individual LoRaWAN end-devices via (constellation of) LEO satellite, first of all implies that the LoRaWAN gateways are mounted on the satellites. Such configuration face several challenges, such as scalability issues: current satellite networks are not designed to support hundred of millions

of direct connections. Even though tricky, this scenario is foreseen to give a raise to a means of new, diverse business models, and market opportunities. For instance, satellite operators may provide e2e connectivity, and charge per number of connected LoRaWAN device, rather than per data transmitted over the satellite links [5].

In case of indirect access, as depicted in Fig. 1, the satellite segment offers the reliable connectivity between the LoRaWAN gateways and the remote server. Each LoRaWAN gateway serves many IoT devices in local area trough LoRaWAN protocol. And then it provides connectivity to the satellite infrastructure. The satellite segment includes a satellite terminal, the GEO satellite, and the satellite gateway. This configuration comes with less system costs, and reduced complexity for installation. Thus, we focus on it in our further analysis.

A. Open Challenges and Research Directions

Hereafter we discuss some of the challenges to face to integrate satellite and LoRaWAN networks, and the modifications of the LoRaWAN protocol that may be needed to ensure high performance over the hybrid network.

1) *Synchronization*: According to *LoRaWAN 1.1 Regional Parameters* specifications [15], in *LoRaWAN Mode A*, the time elapsing between the end of a frame transmission, and the opening of the first and second receiving window is equal to 1 sec, and 2 sec, respectively. By exchanging signalling messages between the end-devices and the gateways, it is possible to change such default values.

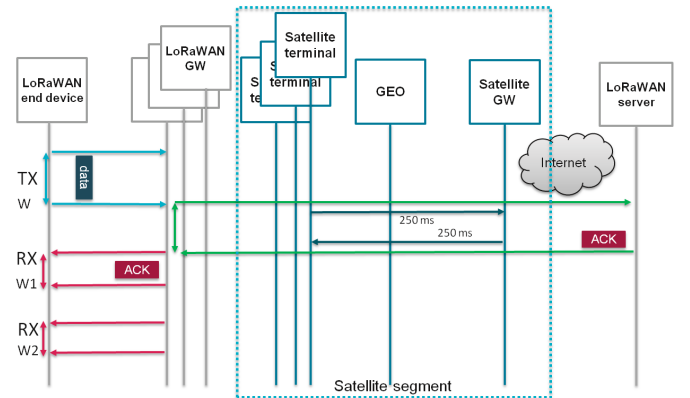

Fig. 4. LoRaWAN Mode A with satellite backhaul

The insertion of the GEO-based satellite link introduces a round trip time (RTT) delay of 500-600 ms. Thus, it may happen that the gateway is not able to forward the ACK within the two receiving windows, if this was not delivered on time from the remote server, over the satellite link. This raise two research questions: how to set up the LoRaWAN parameters, according to satellite network conditions, and ensure successful delivery of the ACK? How to combine *Mode B* and *Mode A* on the LoRaWAN end-devices, and use ping slots to receive ACK (or data) that could not be delivered within the receiving windows? Appropriate solutions should

be designed, keeping the power consumption of the end-device low, being this one of the main IoT requirement.

2) *LoRaWAN Gateway Selection and Replicas Cancellation*: according to the current implementation of the standard [16], all the LoRaWAN gateways within the transmission range of a given end-device, receive the frame that it transmits. Those that are able to correctly decode the frame and extract the encapsulated payload, forward it to the remote server. This will result in several copies of the same data sent over the satellite link. And it may translates in waste of bandwidth over the satellite return channel. And also in longer latency to delivery all the copies to the server, and receive the ACK back. Therefore, in the integrated satellite-LoRaWAN network it could be more efficient to select a priori a subset of gateways, among those in the visibility of the end-device, which communicate with the server. Another option could be to operate the selection of the subset of gateways according to the network conditions (collision, interference) on the satellite terminal. In the case of end-devices communicating in *Mode B*, following a schedule, without incurring in collision, even a single gateway could be selected as forwarding node between and end-device and the server. In the absence of traffic from that gateway for a period of time longer than a pre-established threshold, the server could select another LoRaWAN gateway.

3) *Cross-layer Optimization*: While LoRa and LoRaWAN will be implemented respectively at the PHY and MAC layer, the data generated by the end-device will be encapsulated into an application protocol. A very recent work [21] has addressed this issue, and compared the Protocol Buffers (Protobuf) data format with MQTT-JSON, showing that the first outperform the second, over a Iridium Short Burst Data satellite network. Many studies have been conducted so far to optimize CoAP and MQTT application protocols, for communication over satellite [22]–[24], but not in the context of a LPWAN network. Thus, this is still an area of research to investigate. Moreover, the LoRaWAN MAC parameters should be tuned taking into account also the MAC schemes used for resource allocation on the satellite channel, to guarantee the target Quality of Service (QoS), over the e2e hybrid system.

IV. CONCLUSION

Deploying satellite connectivity to complement terrestrial networks for IoT applications will transform the IoT into the *Internet of Everything Everywhere*. In this paper we describe how to enable IoEE with LPWAN (LoRaWAN in particular) and a GEO-based satellite segment. LPWAN is a promising technology for the IoT segment, due to its long coverage range, low power consumption, and low cost. Moreover, the feasibility of the proposed solution is proved by first use cases already deployed by satellite operators and LPWAN network providers. This paper outlines the main technical challenges to overcome to enable interoperability between satellite systems and LoRaWAN networks.

REFERENCES

[1] M. Palattella, M. Dohler, L. Grieco, G. Rizzo, J. Torsner, T. Engel, and L. Ladid, "Internet of things in the 5G era: Enablers, architecture, and

business models," *IEEE Journal on Selected Areas in Communications*, vol. 34, no. 3, pp. 510–527, Mar. 2016.

[2] U. Raza, P. Kulkarni, and M. Sooriyabandara, "Low power wide area networks: An overview," *IEEE Communications Surveys Tutorials*, vol. 19, no. 2, pp. 855–873, Secondquarter 2017.

[3] P. Thubert, A. Pelov, and S. Krishnan, "Low-power wide-area networks at the IETF," *IEEE Communications Standards Magazine*, vol. 1, no. 1, pp. 76–79, Mar. 2017.

[4] M. De Sanctis, E. Cianca, G. Araniti, I. Bisio, and R. Prasad, "Satellite communications supporting internet of remote things," *IEEE Internet of Things Journal*, vol. 3, no. 1, pp. 113–123, Feb 2016.

[5] [iotuk.org, Satellite Technologies for IoT Applications](https://iotuk.org.uk/wp-content/uploads/2017/04/Satellite-Applications.pdf), 2017. [Online]. Available: <https://iotuk.org.uk/wp-content/uploads/2017/04/Satellite-Applications.pdf>

[6] *Inmarsat Press Releases*, <https://www.inmarsat.com/press-release/inmarsat-actility-deliver-worlds-first-global-lorawan-iot-network-empowering-business-applications/>, 2017.

[7] T. Telkamp, *LoRaWAN from Space*, 2018. [Online]. Available: <https://www.youtube.com/watch?v=VMHejtQEzF4>

[8] A. Abbasi and M. Younis, "A survey on clustering algorithms for wireless sensor networks," *Computer Communications*, vol. 30, no. 14, pp. 2826 – 2841, 2007.

[9] M. Palattella, N. Accettura, X. Vilajosana, T. Watteyne, L. Grieco, G. Boggia, and M. Dohler, "Standardized protocol stack for the internet of (important) things," *IEEE Communications Surveys Tutorials*, vol. 15, no. 3, pp. 1389–1406, Third 2013.

[10] N. Accettura, E. Alata, P. Berthou, D. Dragomirescu, and T. Monteil, "Addressing scalable, optimal, and secure communications over LoRa networks: Challenges and research directions," *Internet Technology Letters*, vol. 1, no. 4, p. e54, 2018.

[11] "Sigfox," [Online] <https://www.sigfox.com>, Aug. 2018.

[12] Y. Wang, X. Lin, A. Adhikary, A. Grovlen, Y. Sui, Y. Blankenship, J. Bergman, and H. Razaghi, "A primer on 3GPP narrowband internet of things," *IEEE Communications Magazine*, vol. 55, no. 3, pp. 117–123, March 2017.

[13] LoRa Alliance Technical Committee, *LoRaWAN™ 1.1 Specification*, Oct. 2017, v1.1.

[14] Semtech, *LoRa™ Modulation Basics, AN1200.22, Revision 2*, May 2015, aN1200.22.

[15] LoRa Alliance Technical Committee, *LoRaWAN™ 1.1 Regional Parameters*, Oct. 2017, v1.1.

[16] —, *LoRaWAN™ Backend Interfaces 1.0 Specification*, Oct. 2017, v1.0.

[17] N. Accettura, B. Prabhu, and T. Monteil, "Simulating scalable long range wide area networks for very low power monitoring applications," in *Proc. of the 22nd International Congress on Modelling and Simulation. Modelling and Simulation Society of Australia and New Zealand*, 2017.

[18] ETSI, *ETSI EN 300 220-2 V3.1.1 (2017-02): Short Range Devices (SRD) operating in the frequency range 25 MHz to 1 000 MHz; Part 2: Harmonised Standard covering the essential requirements of article 3.2 of Directive 2014/53/EU for non specific radio equipment*, Feb. 2017, v3.1.1.

[19] B. G. Evans, "The role of satellites in 5G," in *Advanced Satellite Multimedia Systems Conference and the 13th Signal Processing for Space Communications Workshop (ASMS/SPSC)*, 2014 7th. IEEE, 2014, pp. 197–202.

[20] Z. Qu, G. Zhang, H. Cao, and J. Xie, "LEO satellite constellation for internet of things," *IEEE Access*, vol. 5, pp. 18 391–18 401, 2017.

[21] I. Lysogor, L. Voskov, and S. Efremov, "Survey of data exchange formats for heterogeneous LPWAN-satellite IoT networks," in *2018 Moscow Workshop on Electronic and Networking Technologies (MWENT)*, March 2018, pp. 1–5.

[22] D. Giotti, L. Lamorte, R. Soua, M. Palattella, and T. Engel, "Performance analysis of CoAP under satellite link disruption," in *25th International Conference on Telecommunications (ICT)*, June 2018.

[23] M. Bacco, M. Colucci, and A. Gotta, "Application protocols enabling internet of remote things via random access satellite channels," in *2017 IEEE International Conference on Communications (ICC)*, May 2017, pp. 1–6.

[24] M. Collina, M. Bartolucci, A. Vanelli-Coralli, and G. E. Corazza, "Internet of things application layer protocol analysis over error and delay prone links," in *2014 7th Advanced Satellite Multimedia Systems Conference and the 13th Signal Processing for Space Communications Workshop (ASMS/SPSC)*, Sept 2014, pp. 398–404.