



**HAL**  
open science

## **Parseval's Theorem Used for the Inductor Analysis in High-Frequency Boost Converters**

A. Gutiérrez, Emmanuel Marcault, Corinne Alonso, Jean Paul Laur, David Trémouilles

► **To cite this version:**

A. Gutiérrez, Emmanuel Marcault, Corinne Alonso, Jean Paul Laur, David Trémouilles. Parseval's Theorem Used for the Inductor Analysis in High-Frequency Boost Converters. ELECTRIMACS 2019 Selected Papers, pp.347-362, 2020, 978-3-030-56970-9. <10.1007/978-3-030-56970-9\_26>. <hal-03100915>

**HAL Id: hal-03100915**

**<https://laas.hal.science/hal-03100915v1>**

Submitted on 6 Jan 2021

**HAL** is a multi-disciplinary open access archive for the deposit and dissemination of scientific research documents, whether they are published or not. The documents may come from teaching and research institutions in France or abroad, or from public or private research centers.

L'archive ouverte pluridisciplinaire **HAL**, est destinée au dépôt et à la diffusion de documents scientifiques de niveau recherche, publiés ou non, émanant des établissements d'enseignement et de recherche français ou étrangers, des laboratoires publics ou privés.



HAL Authorization

# Parseval's Theorem for the Inductor Analysis in High-Frequency Power Converters

A. Gutierrez <sup>1\*</sup>, E. Marcault <sup>1</sup>, C. Alonso <sup>2</sup>, J-P. Laur <sup>2</sup>, D. Tremouilles <sup>2</sup>

<sup>1</sup>*CEA-Tech Occitanie, Toulouse - France.* <sup>2</sup>*LAAS-CNRS, Toulouse - France*

---

## Abstract

Advances in GaN-HEMT devices have encouraged the development of power converters at megahertz-level. However, inductors for high-frequency power converters require innovative approaches to overcome challenging constraints in both power and frequency. In this context, this paper presents an extension of the Parseval's theorem for the inductor analysis based on the energy conservation principle in the time and the frequency domains. Our approach aims to provide insights about the inductor power losses using high-frequency parameters and the inductor current harmonics. The proposed approach disaggregates the power losses in the frequency-domain for the inductor power signals in the time-domain. Main findings from the presented methodology provide useful selection criteria for inductors in power converters given parameters of quality factor ( $Q$ ) and Self Resonance Frequency ( $SRF$ ). Simulation results show the impact of the inductor behavior on the switching losses. An experimental setup validates the proposed approach. A high-frequency boost converter is presented as a study case.

*Keywords:* Power Inductor, Quality Factor, Self Resonance Frequency, Boost Converter, GaN-HEMT.

---

## 1. Introduction

<sup>1</sup> Traditional analysis of power converters requires design tools intended to  
<sup>2</sup> deal with operation frequencies around hundreds of kilohertz [1]. However,  
<sup>3</sup> outstanding advances in Gallium Nitride - High Electron Mobility Transis-  
<sup>4</sup> tors (GaN-HEMTs) enlarge the operation condition of power converters to

---

\*Corresponding author: [alonso.gutierrezgaleano@cea.fr](mailto:alonso.gutierrezgaleano@cea.fr)

5 the range of megahertz [2][3]. Indeed, this extended bandwidth requires in-  
6 novative design methodologies to achieve a trade-off between high-frequency  
7 and high-power conditions [4]. Additionally, these new generation of power  
8 converters should incorporate power inductors with both high current han-  
9 dling and high operation frequency [5][6].

10

11 As result, high-frequency parameters become more and more important  
12 for the analysis and selection of inductors during the design process of power  
13 converters [7][8]. Usually, applications of inductors in high-frequency take  
14 into account the manufacturer parameters of Self Resonance Frequency (*SRF*)  
15 and quality factor (*Q*). These *SRF* and *Q* parameters allow describing the  
16 inductor operation bandwidth and the associated power losses. However,  
17 these inductor parameters are few analyzed in the conventional design of  
18 power converters at kilohertz-level. Conversely, operation at megahertz-level  
19 should include the *SRF* and *Q* parameters in the design stage.

20

21 Additionally, the switching improvements provided by GaN-HEMTs can  
22 extend the operation frequency of power inductors to levels usually dedi-  
23 cated to radio-frequency applications. However, manufacturing constrains  
24 associated to ferromagnetic cores limit the scope of power inductors in high-  
25 frequency applications [9]. Therefore, manufacturing features and power-  
26 frequency behavior require a suitable trade-off to improve the inductor per-  
27 formance in high-frequency power converters [10][11].

28

29 In this context, we proposed an innovative approach using the Parseval's  
30 theorem as a means to associate the power losses in the time-domain and the  
31 inductor behavior in the frequency-domain. The developed framework aims  
32 to be complementary to conventional and well known methodologies for the  
33 inductor selection and design of power converters. This approach provides  
34 insights about the impact of the quality factor (*Q*) and the Self Resonance  
35 Frequency (*SRF*) on the inductor current harmonics and the power losses.  
36 Simulation results suggest suitable criteria for a trade-off between the quality  
37 factor (*Q*) and the power losses given feasible manufacturing features. Fur-  
38 thermore, this paper proposes an inductor model incorporating the *Q* and  
39 *SRF* parameters into a circuital model useful for the analysis of power con-  
40 verters.

41

42 This paper is organized as follows. Section 2 describes the power and fre-

43 quency behavior of power inductors considering high-frequency parameters.  
 44 Section 3 presents the theoretical approach based on the Parseval's theorem  
 45 to study the relation between power and frequency. Section 4 describes the  
 46 proposed inductor model including SRF and  $Q$  parameters. Section 5 ex-  
 47 plains in detail the experimental setup to validate the proposed approach.  
 48 Finally, an experimental high-frequency boost converter is implemented.

## 49 2. Power inductor behavior in high-frequency

50 This section describes the inductor behavior in a high-frequency power  
 51 converter taking into account the quality factor ( $Q$ ) and the Self Resonance  
 52 Frequency ( $SRF$ ). A high-frequency boost converter is presented as an il-  
 53 lustrative example.

54  
 55 Fig. 1 shows the designed boost converter as a study case using a com-  
 56 mercial reference of a power inductor. The switching frequency is set to  
 57 30MHz to take advantage of the switching characteristics of GaN-HEMTs.  
 58 This boost converter increases the voltage from 200V to 400V with output  
 59 power of 400W and load of  $400\Omega$ . In this design, the inductor is set to  
 60  $8.2\mu\text{H}$  and the output capacitance is set to 220pF. Furthermore, the studied  
 61 converter focuses on the inductor performance considering ideal the other  
 62 components to avoid their influence in the developed analysis.

63

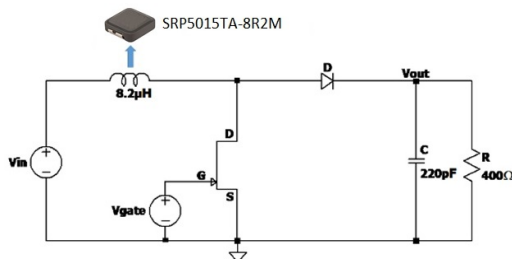

Figure 1: High-frequency boost converter with actual inductor and ideal associated components.

64 Fig. 2 depicts the frequency behavior of the associated inductor losses  
 65  $R_f$  and the quality factor  $Q_f$  for the power inductor of  $8.2\mu\text{H}$  used in the  
 66 designed boost converter. Additionally, Fig. 2 shows the  $SRF$  of the stud-  
 67 ied power inductor. The inductive characteristics prevail in the region of

68 frequencies lower than the  $SRF$  and the capacitive characteristics prevail  
 69 in frequencies higher than the  $SRF$ .  $R_f$  and  $Q_f$  of Fig. 2 are calculated  
 70 using the inductor model provided by the manufacturer. The  $R_f$  and  $Q_f$   
 71 parameters depend on the actual inductor impedance  $Z = |Z| \angle \theta$ . The as-  
 72 sociated losses  $R_f$  are defined as the real part of the inductor impedance  
 73 by  $R_f = |Z| \cos \theta$ . The quality factor  $Q_f$  expresses the relation between the  
 74 stored and dissipated energy. The quality factor  $Q_f$  in an inductor is given  
 75 by  $Q_f = X_L/R_f = \tan \theta_L$ , where  $X_L = |Z| \sin \theta$ .  
 76

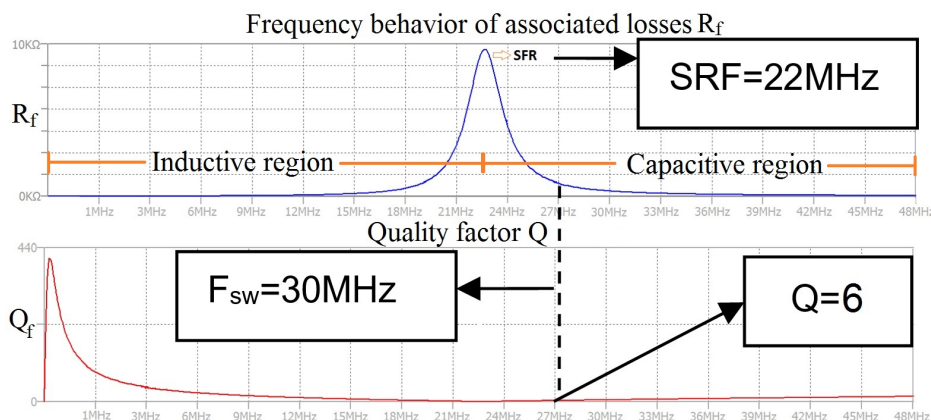

Figure 2: Frequency behavior of  $R_f$  and  $Q_f$  for the power inductor used in the designed boost converter.

77 The power inductor under study accomplish the requirements of induc-  
 78 tance and current in the range of KHz. However, it has a low performance  
 79 in the range of MHz as shown in Fig. 2. The proposed analysis intentionally  
 80 begins with this unsuitable inductor to assess and understand the influence  
 81 of the high-frequency parameters in the inductor performance. This analysis  
 82 is the first step to define selection criteria for high-frequency power inductors  
 83 with a suitable trade-off between performance and feasibility.

84  
 85 Fig. 3 shows the simulation results comparing the inductor current in the  
 86 case of an ideal inductor in series with a low resistance and the manufacturer  
 87 model for the studied inductor. In addition, Fig. 4 illustrates the current har-  
 88 monic spectrum of the inductor under analysis. Results from Fig. 2 to Fig.  
 89 4 show that the unsuitable  $SRF$  causes distortion in the inductor current  
 90 given the harmonics in the capacitive region beyond of the  $SRF$  of 22MHz.

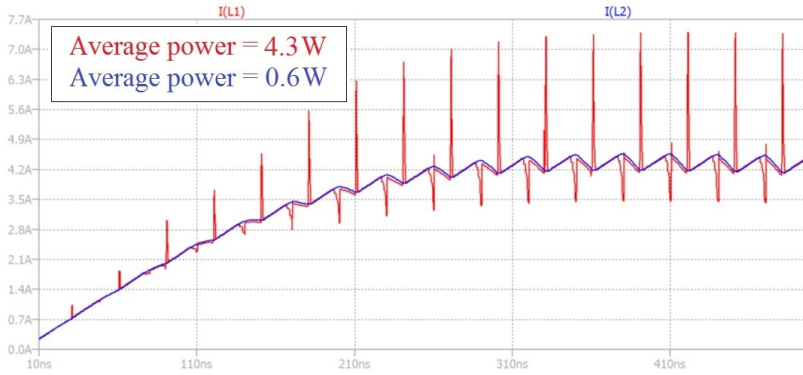

Figure 3: Inductor current. Color nomenclature: blue – ideal inductor in series with a low resistance, red – inductor under study.

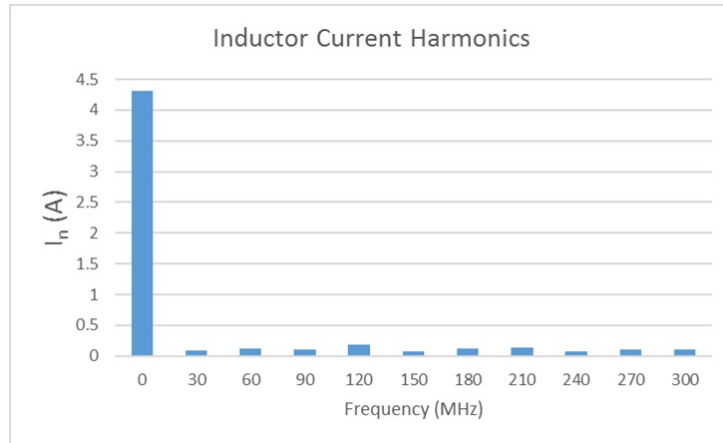

Figure 4: Current harmonic spectrum for the studied inductor.

91 In addition, the low  $Q$  parameter causes important power losses in compari-  
 92 son with the ideal inductor in series with a low resistance. These power losses  
 93 in the time-domain are associated to the interactions between the inductor  
 94 harmonics and the inductor behavior in high-frequency. Next section will  
 95 discuss these interactions using the Parseval's theorem, which describes the  
 96 energy conservation in the frequency-domain and the time-domain.

97

98 **3. Parseval's theorem approach**

99 As described in the previous study case, the wrong selection of the power  
 100 inductor leads to low signal quality and higher losses in high-frequency power  
 101 converters. As a result, the following theoretical approach provides insights  
 102 about the relation between power and frequency of inductors suitable for  
 103 high-frequency power converters.

104  
 105 Considering the approach described in [12] and defining the inductor cur-  
 106 rent  $i(t)$  and the inductor voltage  $v(t)$ , the electrical energy  $U_L$  for an inductor  
 107 in the time-domain is given by eq.(1).

$$U_L = \int_{-\infty}^{\infty} p(t) dt = \int_{-\infty}^{\infty} i(t)v(t) dt \quad (1)$$

109

110

111 In the frequency-domain, the convolution theorem applied to the power  
 112 expression  $i(t)v(t)$  of eq.(1) is given by eq.(2),

113

$$\mathcal{F}\{i(t)v(t)\} = I(f) * V(f) \quad (2)$$

114

115

116 where  $I(f), V(f)$  are the complex valued Fourier transforms.  $\mathcal{F}$  denotes  
 117 Fourier transform, and  $*$  denotes convolution. By definitions of Fourier trans-  
 118 form  $\mathcal{F}$  and convolution, the eq.(2) becomes eq.(3),

119

$$\int_{-\infty}^{\infty} i(t)v(t) e^{-j2\pi\sigma} dt = \int_{-\infty}^{\infty} I(f)V(\sigma - f) df \quad (3)$$

120

121

122 the evaluation of the Fourier transform at the origin ( $\sigma = 0$ ) equals the  
 123 integrals over all their domains [REF REF]. Thus, the electrical energy  $U_L$   
 124 from eq.(1) can be expressed by eq.(4), where  $\overline{V(f)}$  is the complex conju-  
 125 gated of  $V(f)$ ,

126

$$\int_{-\infty}^{\infty} i(t)v(t) dt = \int_{-\infty}^{\infty} I(f)\overline{V(f)} df \quad (4)$$

127

128

129

therefore,

130

$$\int_{-\infty}^{\infty} i(t)v(t) dt = \int_{-\infty}^{\infty} I(f)\overline{[I(f)Z(f)]} df = \int_{-\infty}^{\infty} I(f)^2\overline{Z(f)} df \quad (5)$$

131

132

133

134

given that  $Z(f) = R_f + jX_L$  is the complex impedance of the inductor and  $X_L$  is an odd function [12],

135

$$\int_{-\infty}^{\infty} i(t)v(t) dt = \int_{-\infty}^{\infty} |I(f)|^2 (R_f - jX_L) df = \int_{-\infty}^{\infty} |I(f)|^2 R_f df \quad (6)$$

136

137

138

139

140

141

142

143

144

the result in eq.(6) illustrates the energy conservation between the time and the frequency domains. Therefore, eq.(6) can be seen as an extension of the Parseval's theorem [12]. The physical interpretation of eq.(6) is that the total energy  $U_L$  of the inductor can be calculated by integrating power over time or by the spectral power across frequency known the current and the associated losses. The Parseval's identity define the relation between the average power of a signal  $h(t)$  and their Fourier coefficients as,

145

$$\frac{1}{T} \int_{-T/2}^{T/2} |h(t)|^2 dt = \sum_{n=-\infty}^{\infty} |C_n|^2 \quad (7)$$

146

147

148

149

therefore, the average inductor power can be expressed from eq.(6) by,

$$P_{AVG} = \frac{1}{T} \int_0^T i(t)v(t) dt = \sum_{n=0}^N I_n^2 R_f \quad (8)$$

150

151

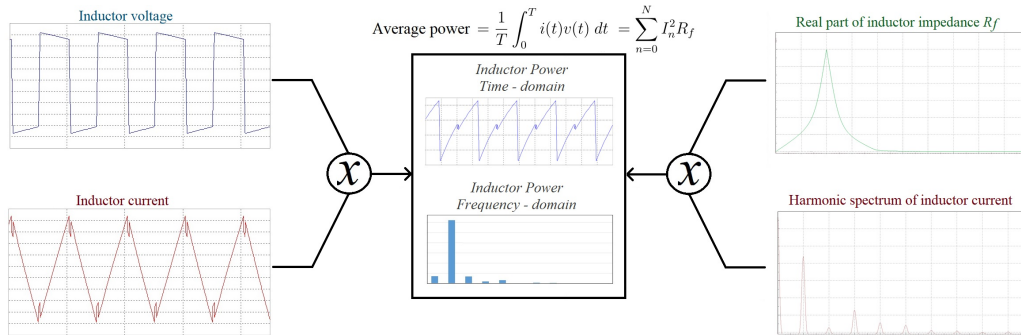

Figure 5: Extension of Parseval's theorem for the inductor analysis in power converters.

152 As a result, the average inductor power depends on the current harmonics  
 153  $I_n$  and the associated inductor losses  $R_f$  from the real part of the inductor  
 154 impedance in the frequency-domain. Fig. 5 depicts an illustrative interpretation  
 155 of the developed concept about the equivalence between the power  
 156 in the time and the frequency domains. The right side criterion of eq.(8)  
 157 is applied to the designed boost converter by means of the associated inductor  
 158 losses  $R_f$  and the current harmonics (see Fig. 2 and Fig. 4). The results  
 159 for the average power in the time and frequency domains are summarized in  
 160 Fig. 6 and Fig. 7. These results agree with the expected energy conservation  
 161 criterion.

162

163 Fig. 7 depicts the distribution of power losses in the frequency domain.  
 164 Results in Fig. 7 show that harmonics higher than eight times the switching  
 165 frequency  $F_{sw}$  have a negligible impact on the power losses. In addition, this  
 166 figure allows highlighting the contribution to the power losses of the current  
 167 at the switching frequency. In this case, the higher losses are given at  
 168 the switching frequency  $F_{sw}$  despite of the very high ratio between the DC  
 169 current and the current at  $F_{sw}$ . The relative high value of  $R_f$  explains this  
 170 power losses at the switching frequency  $F_{sw}$ . Therefore, it is fundamental  
 171 to increase the quality factor  $Q$  to decrease the  $R_f$  losses at the switching  
 172 frequency  $F_{sw}$  in order to improve the global inductor efficiency.

173

174 Fig. 8 shows the relation of the power losses in the time domain against  
 175 the quality factor at the switching frequency  $Q(F_{sw})$ ,

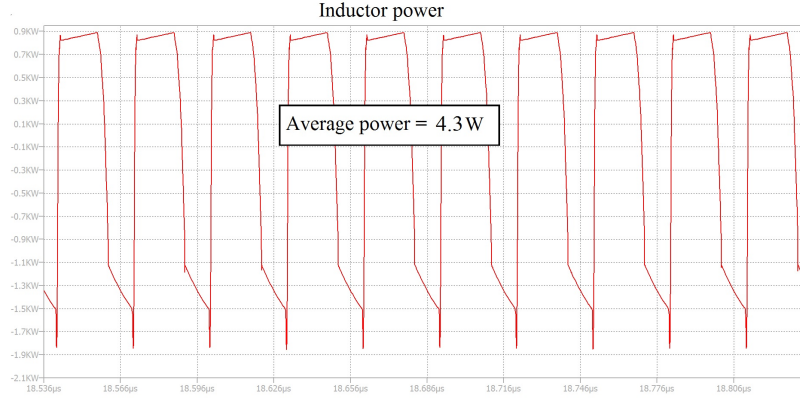

Figure 6: Inductor power in the time-domain.

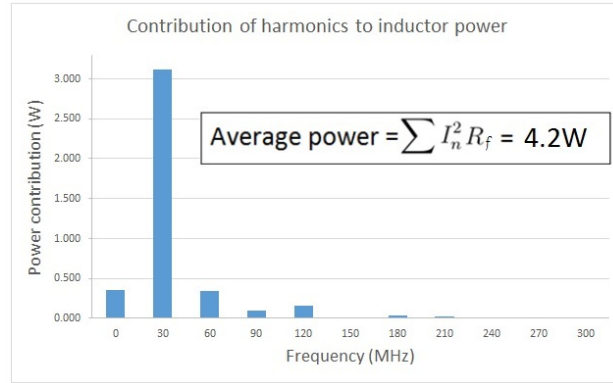

Figure 7: Inductor power in the frequency-domain.

176

$$Q(F_{sw}) = \frac{X_L(F_{sw})}{R_f(F_{sw})} \quad (9)$$

177

178

179

180

181

182

183

184

The plot is calculated from eq.(8) by assuming that the highest contribution to the power losses comes from the fundamental frequency at the switching frequency. To plot this figure, the  $SRF$  is assumed to be eight times the switching frequency  $F_{sw}$  and the  $Q$  factor is evaluated at 30MHz for a fixed current spectrum. Results in Fig. 8 allow concluding that increasing considerably the  $Q$  factor has low impact in the power losses since the

185 reduction in power losses becomes negligible. Therefore, it is necessary an  
 186 approach to the suitable selection of the  $Q$  factor. In this context, the next  
 187 section will propose a circuitual model to include the  $SRF$  and  $Q$  parameters  
 188 in the converter design process to assess their impact in the converter per-  
 189 formance and to further inductor selection or manufacturing.

190

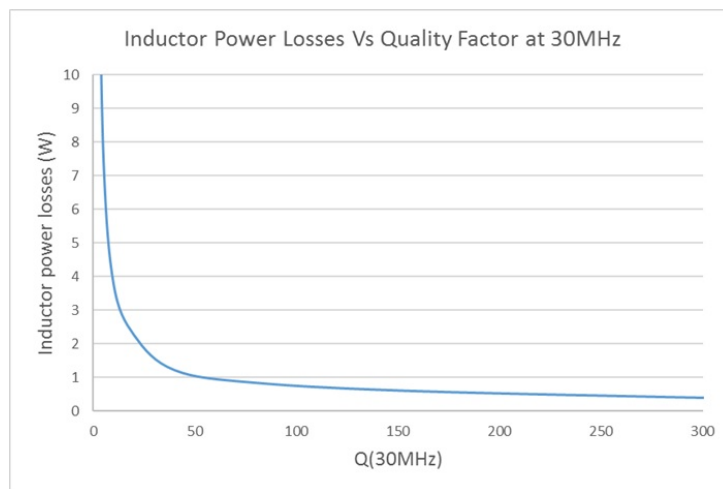

Figure 8: Inductor losses and quality factor  $Q_{sw}$  at the switching frequency  $F_{sw}$ .

#### 191 4. Proposed inductor model including SRF and Q

192 Currently, development of power electronics requires power inductors able  
 193 to operate in high-frequency with high current capabilities. Therefore, the  
 194 manufacturing specifications of  $SRF$  and  $Q$  should be useful to both power  
 195 converter designers and inductor manufactures. As a result, this section pro-  
 196 vides a framework to integrate these parameters in the design process of  
 197 power converters.

198

199 Fig. 9 describes a circuitual model for actual inductors usually used for  
 200 the circuit simulation tools. This model includes an ideal inductor  $L$ , a series  
 201 resistance  $R_s$ , a parasite capacitance  $C_p$ , and a parallel losses resistance  $R_p$ .

202

203 For the inductor model of Fig. 9, the inductor impedance  $Z$  is given by  
 204 the eq.(10) at the switching frequency  $F_{sw}$  and  $\omega_{sw} = 2\pi F_{sw}$ ,

205

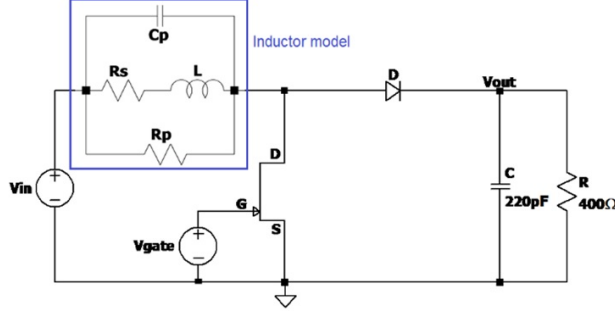

Figure 9: Boost converter with inductor model.

$$Z = \frac{1}{\frac{1}{R_p} + \frac{1 - \omega_{sw}^2 LC_p + j\omega_{sw} C_p R_s}{R_s + j\omega_{sw} L}} \quad (10)$$

206

207

208 considering the real and imaginary parts of  $Z$  and solving for  $Q_{sw}$ , where  
 209  $Q_{sw}$  is defined as the quality factor at the switching frequency  $Q(F_{sw})$ , we  
 210 have,

211

$$Q_{sw} = \frac{Im(Z)}{Re(Z)} = \frac{-R_p (\omega_{sw} C_p R_s^2 - \omega_{sw} L + \omega_{sw}^3 C_p L^2)}{R_s^2 + \omega_{sw}^2 L^2 + R_p R_s} \quad (11)$$

212

213

214 solving for  $R_p$ ,

215

$$R_p = \frac{Q_{sw} (R_s^2 + \omega_{sw}^2 L^2)}{-\omega_{sw}^3 C_p L^2 + \omega_{sw} L - \omega_{sw} C_p R_s^2 - Q_{sw} R_s} \quad (12)$$

216

217

218 Additionally, the  $SFR$  is defined by the inductor resonance frequency.  
 219 Thus, the  $C_p$  capacitance is given by,

220

$$C_p = \frac{1}{(2\pi)^2 (SFR)^2 L} \quad (13)$$

221

222

223 Eq.(12) and eq.(13) allow including in the circuitual inductor model the  
224 high-frequency parameters of Self Resonance Frequency ( $SRF$ ) and the qual-  
225 ity factor at the switching frequency  $Q_{sw}$ . Therefore, these expressions are  
226 useful to simulate and evaluate the impact of the  $SRF$  and  $Q$  parameters on  
227 the power converter performance.

228

229 As illustrative example, the boost converter of Fig. 9 is simulated for  
230  $F_{sw}=30\text{MHz}$ ,  $L=8.2\mu\text{H}$ , and  $R_s=0.2\Omega$ .  $R_p$  and  $C_p$  are calculated from eq.(12)  
231 and eq.(13).  $Q_{sw}=100$  in the analyzed cases. The simulation results of Fig.  
232 10 show the impact on the drain current of the GaN-HEMT transistor when  
233  $SRF$  is evaluated for 30MHz and 250MHz. These results depicts the increas-  
234 ing in the drain current by around 50% which lead to an increase in  
235 the switching losses by around 20%. This phenomenon is mainly generated  
236 by the increase of the parasitic capacitance  $C_p$  when the  $SRF$  parameter is  
237 lower.

238

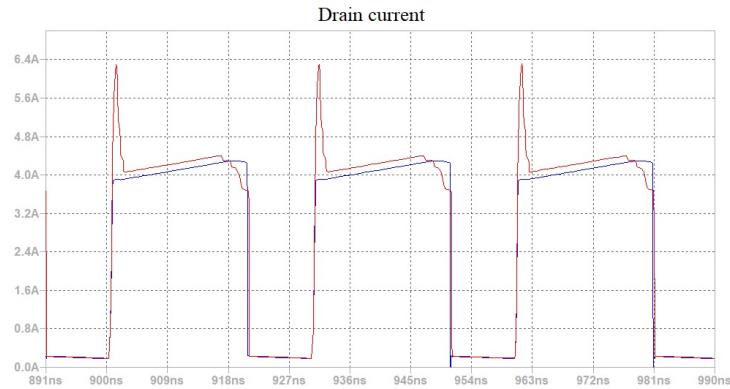

Figure 10: Impact of the  $SRF$  on the drain current. Color nomenclature: blue - drain current for  $SRF=250\text{MHz}$ , red - drain current for  $SRF=30\text{MHz}$ .

239 Fig. 11 depicts the frequency behavior of the associated inductor losses  
240  $R_f$  and the quality factor  $Q_f$  for a power inductor of  $8.2\mu\text{H}$ ,  $Q(30\text{MHz}) = 100$   
241 and  $SRF = 250\text{MHz}$ . Fig. 12 shows the inductor current for the aforemen-  
242 tioned specifications in comparison with an ideal inductor. The frequency  
243 distribution of power losses are plotted in Fig. 13. This figure shows that

244 the selected inductor drastically decreases the power losses at the switching  
 245 frequency.  
 246

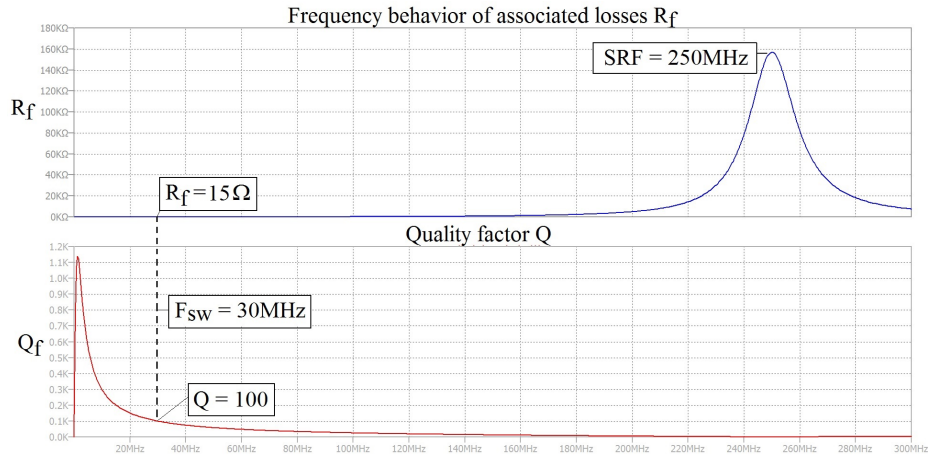

Figure 11: Frequency behavior of  $R_f$  and  $Q_f$  for the modeled inductor.

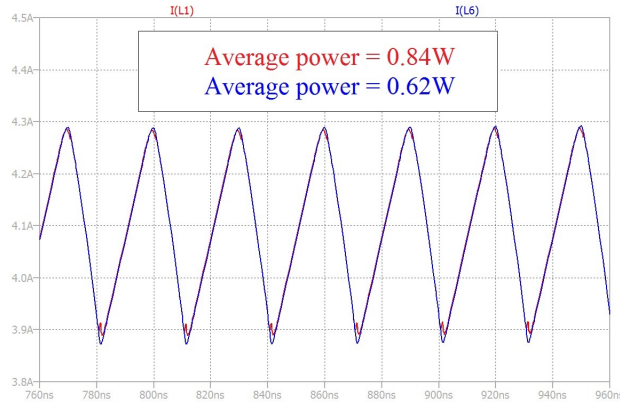

Figure 12: Inductor current. Color nomenclature: blue – ideal inductor with low series resistance, red – power inductor considering  $Q(30\text{MHz}) = 100$  and  $SRF = 250\text{MHz}$ .

247 The proposed analysis for power inductors has been described through  
 248 this document. The simulated results have shown a suitable trade-off be-  
 249 tween power and frequency performance. Next section will introduce the  
 250 experimental setup to validate the proposed approach.

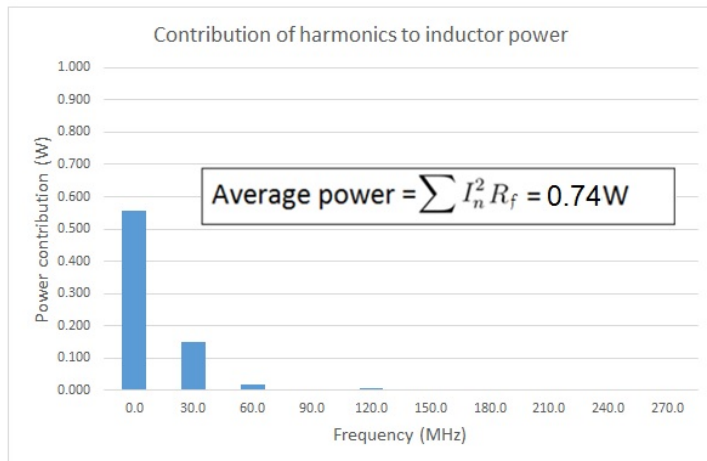

Figure 13: Inductor power distribution in the frequency-domain for  $Q(30\text{MHz})=100$  and  $SRF = 250\text{MHz}$ .

## 251 5. Experimental results

252 This section describes the performed tests. First, the power inductors  
 253 are measured and the circuital models are validated. Then, an experimental  
 254 setup allows verifying the described power equivalence between the time and  
 255 frequency domains. Finally, an experimental boost converter provides results  
 256 about the performance of a conventional power inductor in a relative high-  
 257 frequency.

### 258 5.1. Inductor circuital model and characterization

259 This test employs an impedance analyzer Agilent 4294A to measure the  
 260 parameters of several power inductors. The impedance analyzer sweeps the  
 261 frequency from 40Hz to 110MHz and it measures  $Z - \theta$ ,  $R - X$  and  $L - Q$ .  
 262 Table 1 summarizes the measured and calculated parameters.  $R_p$  and  $C_p$   
 263 calculated from eq.(12) to eq.(13) selecting the  $Q$  factor at 10MHz in all  
 264 cases. Fig. 14 depicts the simulated and measured  $R_f$  (the real part of the  
 265 inductor impedance) for the inductor SRP5015TA. The MAPE (Mean Ab-  
 266 solute Percentage Error) evaluates the model accuracy using eq.(14) where  
 267  $M_K$  is the measured value and  $S_k$  is the simulated value. As listed in Table  
 268 1, the MAPE shows a partial agreement between the experimental data and  
 269 the circuital model.

270

$$MAPE = \frac{1}{n} \sum_{k=1}^n \left| \frac{M_k - S_k}{M_k} \right| \quad (14)$$

271

272

273

274

275

276

277

However, Fig. 14 allows concluding that values for frequencies farther to the selected  $Q$  at 10MHz have less agreement than values around the selected  $Q$ . Therefore, the circuital model can slightly lose accuracy in a wide range of frequencies.

Table 1: Characterization and modeling of inductors

| Inductor Ref.  | Measure                |                               |                | Calculation  |                               |               | MAPE |
|----------------|------------------------|-------------------------------|----------------|--------------|-------------------------------|---------------|------|
|                | L<br>( $\mu\text{H}$ ) | $R_s$<br>( $\text{m}\Omega$ ) | $Q$<br>(10MHz) | SRF<br>(MHz) | $R_p$<br>( $\text{K}\Omega$ ) | $C_p$<br>(pF) |      |
| SRP5015TA-8R2M | 7.8                    | 190                           | 25.5           | 24.2         | 15.3                          | 5.6           | 0.28 |
| SRR1210-8R2Y   | 7.3                    | 4.1                           | 15.4           | 21.1         | 9.1                           | 7.9           | 0.27 |
| 7447713082     | 7.7                    | 29                            | 13.2           | 29.8         | 7.2                           | 3.7           | 0.28 |
| 744314850      | 8.2                    | 24                            | 7.7            | 35.4         | 4.3                           | 2.5           | 0.15 |

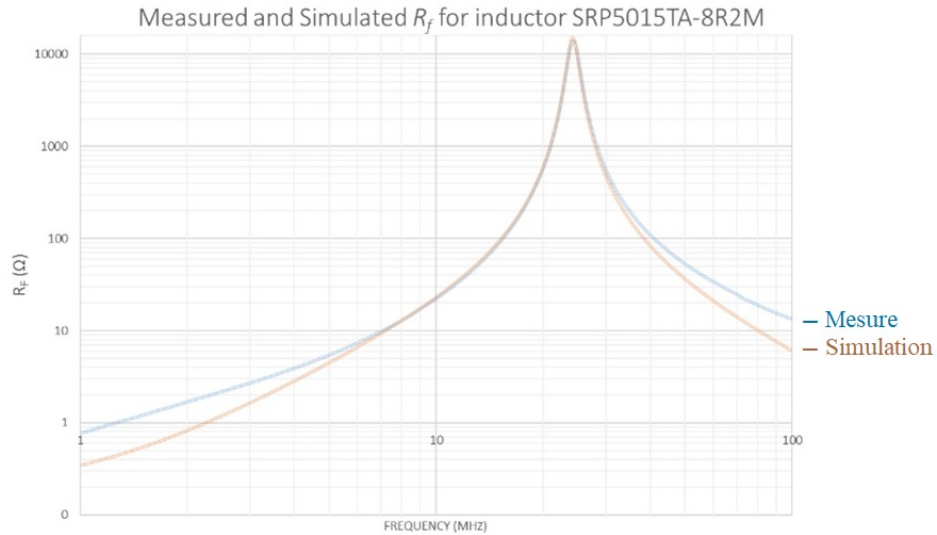

Figure 14: Real part of inductor impedance ( $R_f$ ). Inductor reference SRP5015TA-8R2M.

278 5.2. Inductor power in the time-domain and the frequency-domain

279 In this experimental setup, a waveform generator (33612A Keysight) pro-  
 280 vides a square signal of 5Vpp to the inductor under test. The current probe  
 281 (Tektronix CT2) measures the inductor current, and the active probe(RT-  
 282 ZS20 R&S) measures the voltage. The oscilloscope (RTO-1044 R&S) records  
 283 the waveforms and calculates the average power in the time domain and the  
 284 inductor current FFT (Fast Fourier Transform) in the frequency domain.  
 285 The test is carried out at 10MHz and 30MHz. The aim of this test is to  
 286 validate the power equivalence using the proposed approach.

287  
 288 Fig. 15 depicts the waveforms for square signals of case (a) for 10MHz  
 289 and case (b) for 30MHz for the power inductor SRP5015A. In the case (a),  
 290 the fundamental frequency is lower than the *SRF*. Therefore, the inductor  
 291 is able to store energy as a magnetic field with relative low power loss. In  
 292 contrast, the case (b) has a fundamental frequency higher than the *SRF*. As  
 293 result, the inductor behaves as a capacitor distorting the current signal and  
 294 increasing the power loss.

295  
 296 Fig. 16 shows the FFT for the inductor current of case (a) in Fig. 15a.  
 297 In Table 2, the contribution of each harmonic is calculated from the measured  $R_f$  (see Fig. 14) and the FFT (see Fig. 16) for the fundamental and  
 298 harmonic frequencies using expression eq.(15). Results from Fig. 15a and  
 299 Table 2 agree with the expected correlation between the power in the time  
 300 and frequency domains.

$$P_{AVG} = \frac{1}{T} \int_0^T i(t)v(t) dt = \sum_{n=0}^N I_n^2 R_f \quad (15)$$

303  
 304  
 Table 2: Inductor power frequency-domain (SRP5015A). Test at 10MHz - square signal.

| Freq.(MHz)   | 0    | 10  | 30 | 50  | 70  | 90  | Total |
|--------------|------|-----|----|-----|-----|-----|-------|
| $P_h(\mu W)$ | 0.03 | 197 | 14 | 4.8 | 2.9 | 1.7 | 220   |

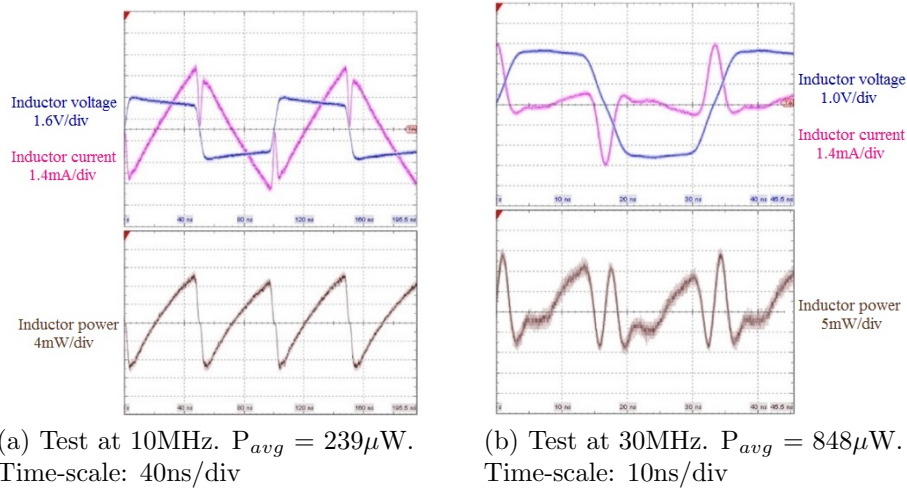

Figure 15: Test inductor SRP5015A at 10MHz and 30MHz.



Figure 16: FFT of inductor current for test at 10MHz - square signal. Inductor reference SRP5015A.

305 Table 3 summarizes the power results for the measured inductors. These  
 306 results confirm the duality between the inductor power in the time-domain  
 307 and the frequency-domain. However, differences between theoretical and  
 308 experimental results are mainly caused by the shifting of the  $SRF$  given the  
 309 parasitic capacitance and inductance of the current and voltage probes.

### 310 5.3. Boost converter at 1MHz

311 This test implements a boost converter at 1MHz. The boost converter  
 312 specification are  $V_{in}=30\text{V}$ ,  $V_{out}=60\text{V}$ ,  $P_{out}=40\text{W}$ , and inductor current  $I_L=1.5\text{A}$

Table 3: Inductor power in the time and frequency

|                         | SRP5015TA-8R2M |       | SRR1210-8R2Y |       |
|-------------------------|----------------|-------|--------------|-------|
|                         | 10MHz          | 30MHz | 10MHz        | 30MHz |
| Power time ( $\mu W$ )  | 239            | 848   | 257          | 925   |
| Power freq. ( $\mu W$ ) | 220            | 760   | 235          | 857   |
|                         | 7447713082     |       | 744314850    |       |
|                         | 10MHz          | 30MHz | 10MHz        | 30MHz |
| Power time ( $\mu W$ )  | 285            | 1380  | 299          | 818   |
| Power freq. ( $\mu W$ ) | 262            | 1140  | 283          | 767   |

313 considering an efficiency  $\eta=0.9$ . The design uses an inductor SRR1210-8R2  
 314 given its favorable quality factor  $Q(1\text{MHz})=30$  and  $SRF=22\text{MHz}$ . The se-  
 315 lected inductor SRR1210-8R2 has a series resistance  $R_s=17\text{m}\Omega$  and a sat-  
 316 uration current of 7.5A. The switching frequency is set to 1MHz to ensure  
 317 the eight harmonic lower than the  $SRF$ . A GaN-HEMT is used as a switch-  
 318 ing device. The achieved results harmonize with the theoretical framework.  
 319 However, the slight deviation between the temporal and frequency responses  
 320 can be overcome by improving the experimental setup decreasing the para-  
 321 sitic elements.

322

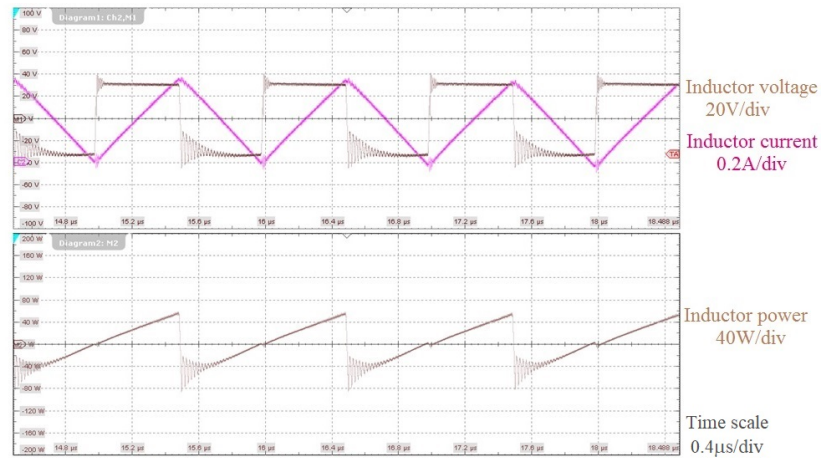

Figure 17: Experimental results for 1MHz boost converter. Inductor SRR1210-8R2.  $P_{avg}=492\text{mW}$ .

323 Fig. 17 shows the inductor waveforms. The inductor average power in the  
 324 time-domain is  $P_{avg}=492\text{mW}$ . Fig. 18 depicts the harmonic spectrum for the  
 325 inductor current. Table 4 lists the power contribution of each harmonic to  
 326 the total power. The total power in the frequency-domain is  $P_{avg}=447\text{mW}$ .  
 327 Results from Fig. 17 and Table 4 validate the equivalence between the power  
 328 in the time and frequency domains. In additions, the results allow identifying  
 329 that the behavior at the fundamental frequency is the main cause of the  
 330 inductor power loss.



Figure 18: FFT for the inductor current of 1MHz boost converter.

Table 4: Inductor power in the frequency domain

| Freq.(MHz)       | 0  | 1   | 2   | 3  | 4    | 5   | Total |
|------------------|----|-----|-----|----|------|-----|-------|
| $P_h(\text{mW})$ | 14 | 418 | 0.4 | 11 | 0.05 | 2.7 | 447   |

#### 331 5.4. Boost converter for 400V - 400W at 30MHz

332 This section shows the results of implementing a high-frequency boost  
 333 converter. A power inductor was designed for this experimental setup. The  
 334 designed inductor has specifications of  $L=8\mu\text{H}$ ,  $I_{sat}=3.5\text{A}$ ,  $Q(30\text{MHz})=25$   
 335 and  $SRF=200\text{MHz}$ . The switching device is a GaN-HEMT.

336

337 The boost converter is tested first at  $V_{out}=60\text{V}$  -  $P_{out}=10\text{W}$  and after at  
 338  $V_{out}=400\text{V}$  -  $P_{out}=400\text{W}$ . The test is carried out first in relative low power  
 339 to use available current probe (Tektronix CT2) because current probes for

340 high-current, high-voltage and high-frequency are currently under develop-  
 341 ment. This represents a research challenge. In the second case, the inductor  
 342 current is not measure for previous reasons. However, the global power con-  
 343 verter results shows the suitable performance of the designed inductor.

344

345 In the first test, the specifications of the boost converter are  $V_{in}=30V$ ,  
 346  $V_{out}=60V$ , and  $P_{out}=10W$  at 30MHz. Fig. 19 shows the waveforms for the  
 347 power inductor. In this case, the average power was  $P_{avg}=780mW$  in the  
 348 time-domain and  $P_{avg}=700mW$  in the frequency-domain.

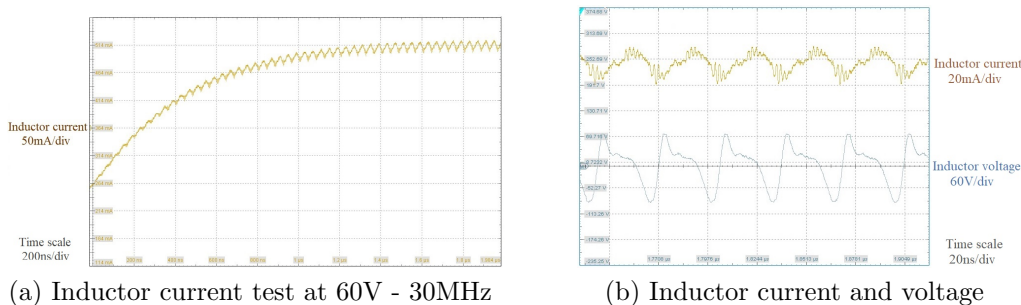

Figure 19: Inductor current and voltage for boost converter 60V - 10W at 30MHz

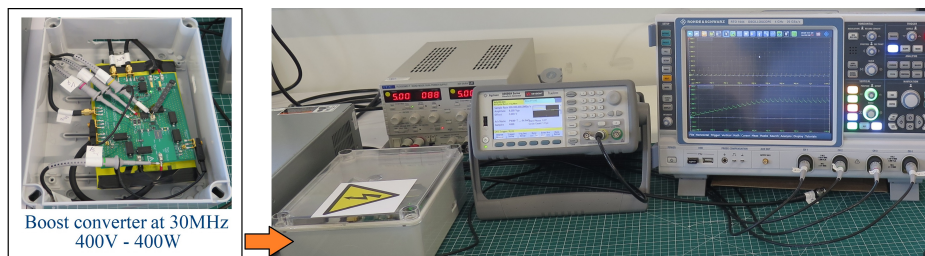

Figure 20: Experimental setup boost converter 400V - 400W at 30MHz.

349 For the second test, the implemented high-frequency boost converter has  
 350 specifications of  $V_{in}=200V$ ,  $V_{out}=400V$ ,  $P_{out}=400W$  at 30MHz. Fig. 20 shows  
 351 the experimental setup for the high-frequency boost converter. Additionally,  
 352 result of Fig. 21 depicts the behavior of the output voltage. As shown in Fig.  
 353 21, the designed boost converter is able to increase the input voltage from  
 354 200V to 400V with an output load of 400W. The switching frequency is set to  
 355 30MHz to assess the GaN-HEMT devices at high-voltage and high-frequency  
 356 given a suitable performance. As a consequence, these results confirm the

357 pertinence of the developed modeling approach to analyze and design power  
 358 inductors to take advantages of the switching characteristics of GaN-HEMT  
 359 devices.

360

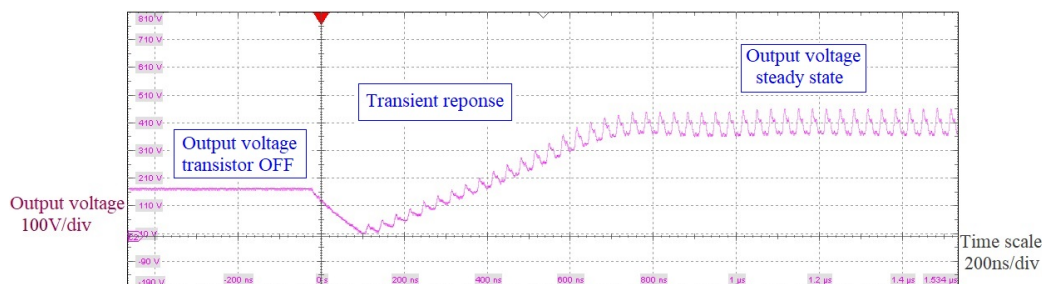

Figure 21: Output voltage of boost converter 400V - 400W at 30MHz.

## 361 6. Conclusions

362 The reported methodology has associated the analysis in the time and  
 363 frequency domains for inductors in power converters using an extension of  
 364 the Parseval's theorem. The proposed approach is complementary to con-  
 365 ventional methodologies for the design of power converters. This analysis  
 366 methodology allowed determining suitable criteria for the selection and sim-  
 367 ulation of inductors according to expected power losses. The proposed ap-  
 368 proach allowed disaggregating the power losses in the frequency-domain for  
 369 complex inductor power signals in the time-domain. The study of the quality  
 370 factor  $Q$  allowed concluding that increasing considerably  $Q$  has low impact  
 371 on the power losses since the reduction in power losses becomes negligible.  
 372 Therefore, a moderate  $Q$  factor can be selected to achieve a trade-off between  
 373 inductor performance and manufacturing feasibility. Additionally, the Self  
 374 Resonance Frequency  $SRF$  around eight times the switching frequency is a  
 375 suitable criterion to avoid inductor current distortion. The proposed model  
 376 in this work included frequency parameters of inductors in the design process  
 377 of power converters. The experimental results have validated the proposed  
 378 approach. However, the experimental setup should decrease the parasitic  
 379 inductance and capacitance to minimize the measurement disturbances at  
 380 high-frequency.

381 **Acknowledgments**

382 This work has been partially funded by the Region Occitanie Pyrenees-  
383 Mediterranee.

384 **References**

- 385 [1] P. Ning, T. Yuan, Y. Kang, C. Han, and L. Li, “Review of si igt  
386 and sic mosfet based on hybrid switch,” *Chinese Journal of Electrical*  
387 *Engineering*, vol. 5, pp. 20–29, Sep. 2019.
- 388 [2] J. Kashiwagi, A. Yamaguchi, Y. Moriyama, and K. Nakahara, “Hys-  
389 teretic control embedded boost converter operating at 25-mhz switch-  
390 ing,” *IEEE Transactions on Circuits and Systems II: Express Briefs*,  
391 vol. 66, pp. 101–105, Jan 2019.
- 392 [3] A. Hariya, K. Matsuura, H. Yanagi, S. Tomioka, Y. Ishizuka, and T. Ni-  
393 nomiya, “Five-megahertz pwm-controlled current-mode resonant dc–dc  
394 step-down converter using gan-hemts,” *IEEE Transactions on Industry*  
395 *Applications*, vol. 51, pp. 3263–3272, July 2015.
- 396 [4] M. Rodríguez, Y. Zhang, and D. Maksimovic, “High-frequency pwm  
397 buck converters using gan-on-sic hemts,” *IEEE Transactions on Power*  
398 *Electronics*, vol. 29, pp. 2462–2473, May 2014.
- 399 [5] A. Hilal and B. Cougo, “Optimal inductor design and material selec-  
400 tion for high power density inverters used in aircraft applications,” in  
401 *2016 International Conference on Electrical Systems for Aircraft, Rail-*  
402 *way, Ship Propulsion and Road Vehicles International Transportation*  
403 *Electrification Conference (ESARS-ITEC)*, pp. 1–6, Nov 2016.
- 404 [6] W. Liang, L. Raymond, and J. Rivas, “3-d-printed air-core inductors for  
405 high-frequency power converters,” *IEEE Transactions on Power Elec-*  
406 *tronics*, vol. 31, pp. 52–64, Jan 2016.
- 407 [7] A. F. Jaimes, F. L. Cabrera, and F. R. de Sousa, “Characterization of  
408 high-  $q$  inductors up to its self-resonance frequency for wireless power  
409 transfer applications,” *IEEE Microwave and Wireless Components Let-*  
410 *ters*, vol. 28, pp. 1071–1073, Dec 2018.

- 411 [8] D. C. Corrêa, U. C. Resende, and F. S. Bicalho, “Experiments with  
412 a compact wireless power transfer system using strongly coupled mag-  
413 netic resonance and metamaterials,” *IEEE Transactions on Magnetism*,  
414 vol. 55, pp. 1–4, Aug 2019.
- 415 [9] Kaiwei Yao, Yang Qiu, Ming Xu, and F. C. Lee, “A novel winding-  
416 coupled buck converter for high-frequency, high-step-down dc-dc conver-  
417 sion,” *IEEE Transactions on Power Electronics*, vol. 20, pp. 1017–1024,  
418 Sep. 2005.
- 419 [10] E. L. Barrios, A. Urtasun, A. Ursúa, L. Marroyo, and P. Sanchis, “Op-  
420 timal dc gapped inductor design including high-frequency effects,” in  
421 *IECON 2015 - 41st Annual Conference of the IEEE Industrial Elec-*  
422 *tronics Society*, pp. 003928–003933, Nov 2015.
- 423 [11] R. Barrera-Cardenas, T. Isobe, and M. Molinas, “Optimal design of air-  
424 core inductor for medium/high power dc-dc converters,” in *2016 IEEE*  
425 *17th Workshop on Control and Modeling for Power Electronics (COM-*  
426 *PEL)*, pp. 1–8, June 2016.
- 427 [12] S. S. Kelkar, L. L. Grigsby, and J. Langsner, “An extension of parseval’s  
428 theorem and its use in calculating transient energy in the frequency do-  
429 main,” *IEEE Transactions on Industrial Electronics*, vol. IE-30, pp. 42–  
430 45, Feb 1983.