



HAL
open science

Battery-free Wireless Sensors for IoT applications

Alexandru Takacs, Gael Loubet, Taki Djidjekh, Lamoussa Sanogo, Daniela Dragomirescu

► **To cite this version:**

Alexandru Takacs, Gael Loubet, Taki Djidjekh, Lamoussa Sanogo, Daniela Dragomirescu. Battery-free Wireless Sensors for IoT applications. 2024 15th International Conference on Communications (COMM), Oct 2024, Bucharest, Romania. pp.1-6, 10.1109/COMM62355.2024.10741486 . hal-04786096

HAL Id: hal-04786096

<https://laas.hal.science/hal-04786096v1>

Submitted on 15 Nov 2024

HAL is a multi-disciplinary open access archive for the deposit and dissemination of scientific research documents, whether they are published or not. The documents may come from teaching and research institutions in France or abroad, or from public or private research centers.

L'archive ouverte pluridisciplinaire **HAL**, est destinée au dépôt et à la diffusion de documents scientifiques de niveau recherche, publiés ou non, émanant des établissements d'enseignement et de recherche français ou étrangers, des laboratoires publics ou privés.

Battery-free Wireless Sensors for IoT applications

1th Alexandru Takacs
LAAS-CNRS, LAAS-CNRS, Université
de Toulouse, CNRS, INSA, UPS
Toulouse, France
atakacs@laas.fr

2nd Gael Loubet
LAAS-CNRS, LAAS-CNRS, Université
de Toulouse, CNRS, INSA, UPS
Toulouse, France
gloubet@laas.fr

3rd Taki Djidjekh
LAAS-CNRS, LAAS-CNRS, Université
de Toulouse, CNRS
Toulouse, France
tedjidjekh@laas.fr

4th Lamoussa Sanogo
LAAS-CNRS, LAAS-CNRS, Université
de Toulouse, CNRS
Toulouse, France
lsanogo@laas.fr

5th Daniela Dragomirescu
LAAS-CNRS, LAAS-CNRS, Université
de Toulouse, CNRS, INSA, UPS
Toulouse, France
daniela@laas.fr

Abstract—This paper highlights the new advances in the field of energy-autonomous battery-free wireless sensors for IoT applications. The design and implementation challenges as well as optimized solutions are presented in a unified approach. At device level, the most relevant hardware architectures are presented with a focus of state-of-art experimental results obtained for battery-free LoRaWAN (Long Range Wide Area Network) and BLE (Bluetooth Low Energy) wireless sensors targeting IoT (Internet of Things) and SHM (Structure Health Monitoring) applications. At system level we are focusing on networks topologies and new security and identification mechanisms implemented on hardware/electromagnetic level by exploiting the wireless power transfer link capabilities in the context of the simultaneously wireless information and power transfer.

Keywords—Battery-Free Wireless Sensor, Wireless Power Transfer, Energy Harvesting, Simultaneous Wireless Information and Power Transfer, Wireless Sensors Network, Internet of Things, Structural Health Monitoring

I. INTRODUCTION

Nowadays, in the context of Internet of Things [1] applications, the use of wireless sensor networks becomes an extensively used solution for many applications including but not limited to Structural Health Monitoring (SHM), automotive, aerospace, smart home, smart cities, intelligent transportation, industry 4.0, etc. A key issue for implementing wireless sensors at such a large scale is related to energy aspects. The energy autonomy of wireless sensors is a major limiting factor for the long-term deployment of Wireless Sensor Networks (WSN). Today, most of the deployed wireless sensors are powered by batteries. However, batteries have a limited lifespan, replacing them requires time, additional costs and involves environmental issues for recycling. A very promising solution for avoiding such issues is the use of battery-free wireless sensors [2] acting as sensing nodes. Active battery-free wireless sensors can be powered by ambient energy harvesting [3-4] or Wireless Power Transfer (WPT) [5], while passive battery-free sensors can be remotely interrogated basically by using RFID or Radar techniques. In the case of remote interrogation of passive sensors, the energy and processing constraints are concentrated solely on reader/interrogator level. Energy harvesting scavenges and convert into dc power the fluctuating, unpredictable and uncontrollable residual energy available in the environment. To be less sensitive of the deployment environment, a controllable power source is used in Wireless Power Transfer solutions to enable the scavenging, at distance, of specifically supplied power. In the case of remote interrogation of passive sensors, processing and energy constraints are concentrated

solely in the interrogator. This paper focuses on the design, implementation and characterization of battery-free wireless sensors powered by radiative/far field wireless power transfer in the context of structural health monitoring and Internet of Things applications. The basics architectures, concepts and topologies of the battery-free wireless sensors are presented in Section II while some recent state-of-art results obtained in the field of battery-free wireless sensor powered by radiative WPT techniques and using LoRaWAN and Bluetooth Low Energy (BLE) communication protocol are highlighted in Section III.

II. ARCHITECTURES, TOPOLOGIES AND CONCEPTS FOR BATTERY-FREE WIRELESS SENSORS

Instead of a battery, the battery-free wireless sensors typically use capacitor/supercapacitor as energy storage element. Capacitor-based solutions are generally preferred because of their inherent advantages in terms of lifetime, cost and thermal behavior. Several fundamental concepts used for implementing state-of-the art battery-free wireless sensors are presented afterward as well as typical architectures and topologies.

A. Wireless Network Sensors: Architecture, Topology, and Concepts

As function of application, the choice and the optimal design of the wireless network topology is a key element. A meshed wireless sensor network was recently proposed by authors [6-8] for structural health monitoring of concrete walls and beams of building and civil engineering infrastructures. The main goal is to perform physical measurements inside concrete structures (i.e. temperature humidity, resistivity, mechanical stress, corrosion, etc.) and to make accessible those data worldwide on Internet. The network is composed by two kind of sensors: Sensing Nodes and Communication Nodes connected in a meshed network as represented in Fig. 1. The Sensing nodes are buried inside concrete structures and once installed there are inaccessible for maintenance during their entire lifetime. Consequently, they must be battery-free and they are used for collecting physical data and transmit those data wirelessly to Communicating Nodes. Because of the operation mode that is battery-free, sensing nodes have limited resources in terms of energy, computing and communication. The data received from Sensing Nodes are assembled, aggregated and shared over Internet by the Communicating Nodes. The Communicating Nodes are provided with a stable and reliable dc or ac energy source and have enough energy and computing resources to perform complex tasks. Communicating Nodes integrates or drives dedicated RF sources (power transmitting sources) used for

generating electromagnetic waves required for the radiative wireless power transfer from RF sources, as downlink to Sensing Nodes.

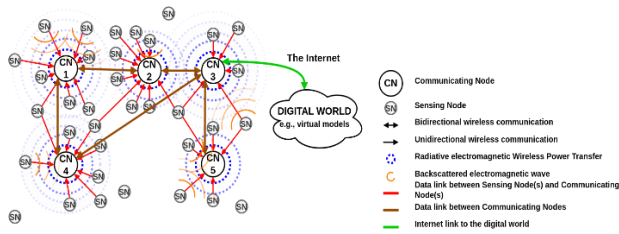

Fig. 1. Typical wireless sensors architecture designed for structural health monitoring of civil engineering architecture

The RF sources are not presented in this paper. Nevertheless, generating RF/electromagnetic waves is subject to regulation and allowed only inside dedicated ISM (International Scientific and Medical) frequency bands. Table I summarize the most used ISM frequency band for radiative wireless power transfer and the main limitations in terms of allowed Effective Isotropic Radiated Power (EIRP).

TABLE I. ISM FREQUENCY BANDS

Frequency band (MHz)	433	868	2450	5800
Free-space wavelength (cm)	69.2	34.4	12.2	5.2
Bandwidth (MHz)	1.74	5	100	150
Maximum EIRP (dBm) according to [9] (Europe)	+10	+33	+20	+23 / +30
Free-space losses (dB) at 1 meter	25.17	31.21	40.23	47.71
Theoretical range (cm) to obtain +0 dBm (or 1 mW) at the output of a 0 dBi antenna for a power source operating at maximum EIRP	17	123	9	6/13
Theoretical range (m) to obtain -17 dBm (or 20.0 μ W) at the output of a 0 dBi antenna for a power source operating at maximum EIRP	1.23	8.69	0.68	0.41 or 0.92

As represented in Table I, ISM 868 MHz band exhibits a good trade of in terms of free-space wavelength (impacting antenna size), free-space losses and the maximum allowed EIRP. From electromagnetic point of view both energy/power and communication/information waveform are exchanged between Communicating Nodes (CN) and Sensing Nodes (SN) as represented in Fig. 2. Thus, the Simultaneous Wireless Information and Power Transfer (SWIPT) concept is implemented in the case of battery-free wireless sensors. SWIPT is an important concept for any successful battery-free design. Typically, different frequency bands are used for wireless data/information and power/energy transfer making easy the simultaneously transfer. When the same frequency band is shared for data and power transfer, more complex solutions should be implemented by using at least two antennas, separate wave polarization or bulky components as circulator. As represented in Fig. 2 the electromagnetic waveform exchanged between CN and SN is composed of: (i) an energy or power-wave basically used for wireless power transfer and

(ii) a data-wave used for data communication between CN and SN. Basically, that data-wave is bidirectional while power-wave is typically unidirectional, downlink from CN to SN, but a backscattering uplink wave can be added in some cases for communication (e.g. for battery-free backscattering sensors [10-13]) or for identification/security purposes [14,15]).

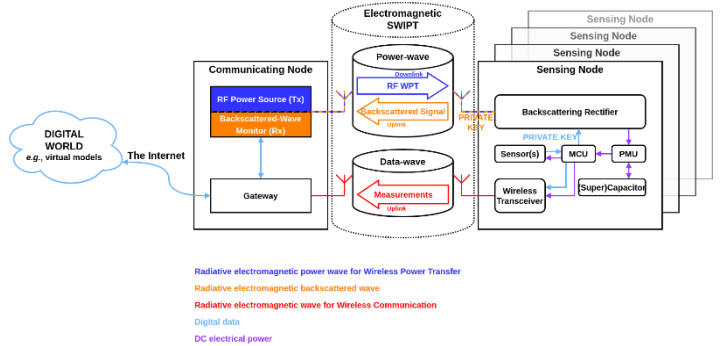

Fig. 2. Illustration of the electromagnetic waves exchanges between Communicating Nodes and Sensing Nodes

B. Battery-free Wireless Sensor Architecture and Topology

A general topology of the battery-free wireless sensor acting as a Sensing Node in the frame of a wireless sensors network is represented in Fig. 3. It is composed of: sensors, a microcontroller unit (MCU), a wireless transceiver, antennas, an energy storage element (supercapacitor or capacitor), a Power Management Unit (PMU) and a rectenna. Most of published designs uses commercially available components with the exception of custom-made rectennas and antennas. The rectenna (acronym of rectifier and antenna) is a key element of this topology allowing the conversion of the received electromagnetic power density into dc power required for proper operation of the overall sensing node. When a backscattered power-wave is generated for identification and security purposes a backscattering rectifier driven by a private key generated by the MCU is used, otherwise a 'standard' rectifier is integrated as part of the rectenna.

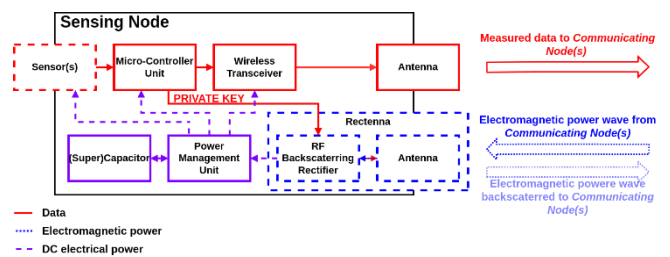

Fig. 3. Typical topology of a battery-free Sensing Nodes power by a radiative far-field wireless power transfer technique. The flow path of data, electromagnetic power and dc power are represented with different colors.

Fig. 4 a) depicts the topology of a standard rectifier connected between the RF input (i.e. the output of antenna used for WPT) and the PMU. It is composed of two Schottky diodes mounted in a voltage doubler topology and L impedance matching circuit. A photo of a compact rectenna integrated with a single series diode rectifier [16,17] is shown in Fig. 4 b) while the photo and electronic schematic of a backscattering rectifier [14,15] is represented in Fig. 4 c). Fig. 5 shows the power conversion efficiency computed as the

ratio between the measured dc power output and the RF input power (that is function of the electromagnetic power density illuminating the rectenna) of the rectifier.

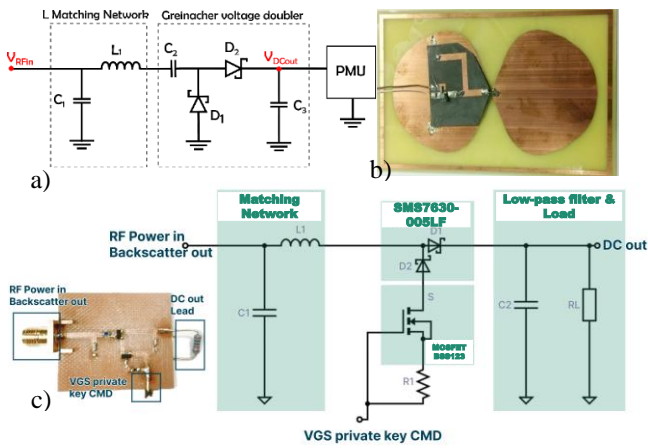

Fig. 4. Topologies and photos of the rectifiers used in battery-free wireless sensors.

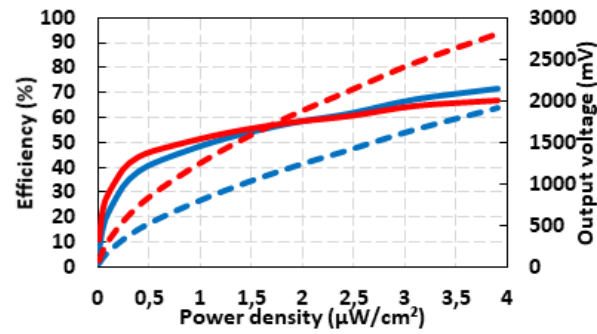

Fig. 5. Power conversion efficiency of the rectenna (full lines) and measured output dc voltage (dashed lines) as function of the electromagnetic power densities at 868 MHz and for a 10-kΩ resistive load emulating the PMU input impedance

III. BATTERY-FREE WIRELESS SENSORS USING LoRaWAN AND BLE COMMUNICATION TECHNOLOGIES

Several battery-free wireless sensors using LoRaWAN and BLE communication protocols have been recently proposed by the authors [6-8], [18,19]. Both of them are able to perform temperature, humidity and resistivity measurements for SHM/IoT applications. LoRaWAN based battery-free wireless sensors integrates an all-in-one CMWX1ZZABZ-091 LoRaWAN module from Murata based on SX1276 LoRa transceiver from Semtech and a STM32L072CZ microcontroller from STMicroelectronics, an HDC2010 from Texas Instruments as a temperature and relative humidity sensor, the power management unit BQ5570 from Texas Instruments and custom-made antenna and rectifier. The same frequency band ISM 868 MHz is shared for data communication and power transfer. The use of a circulator with a single custom-made compact dipole-based antenna allows separating the two signal paths: the energy receiving (Rx) and data sending (Tx). The photos of three versions (prototypes) of manufactured battery-free LoRa-based wireless sensors are represented in Fig. 6. It can be noted the use of the PCB card as metallic reflector for the compact dipole antenna Fig. 7 shows an experimental setup (concrete beam) used for characterizing in real environment the prototypes represented in Fig. 6.

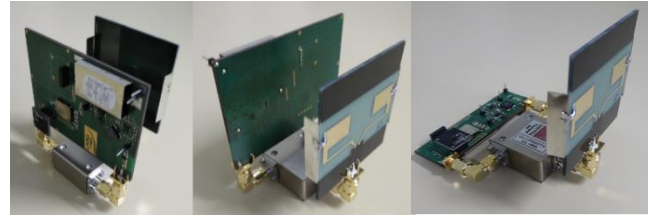

Fig. 6. Photo of manufactured battery-free LoRaWAN wireless sensor.

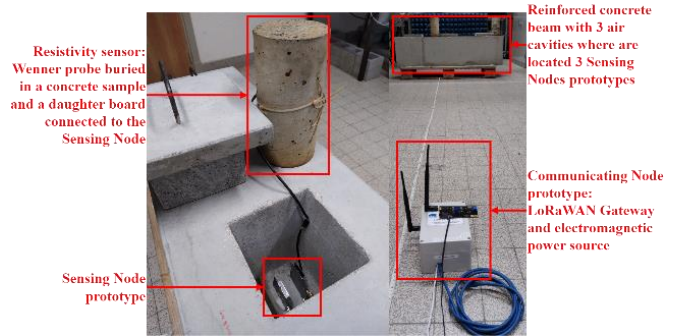

Fig. 7. Photo of the experimental setup in real environment (concrete beam) with a focus on the battery-free LoRaWAN wireless sensor inside of a cavity of a concrete beam and the Communicating Node composed of a LoRaWAN gateway and a custom-made electromagnetic power source

Two prototypes of manufactured battery-free wireless sensors using wireless power transfer and BLE technologies are represented in Fig. 8. Both of them uses a BLE System-on-Chip QN9080 from NXP and custom-made rectifiers (with two Schottky diodes mounted in a doubler topology as represented in Fig. 4 a) and antennas.

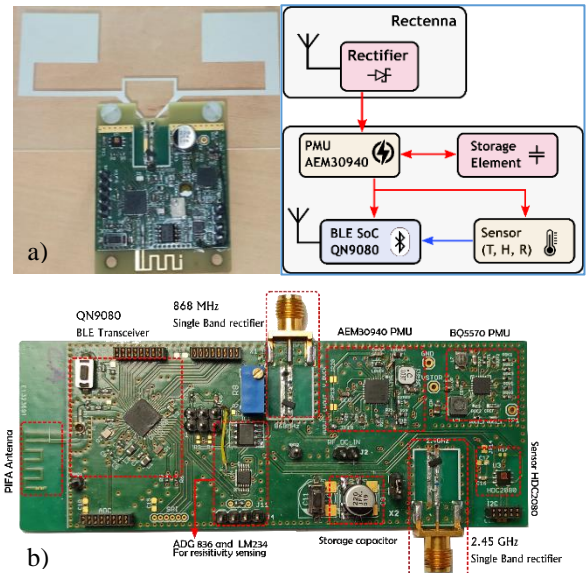

Fig. 8. Manufactured battery-free BLE sensors: a) photo and topology of a BLE battery-free wireless sensors using a flexible compact folded dipole antenna for wireless power transfer (868 MHz), a planar Inverted F antenna for BLE communication (2.45 GHz) and AEM30940 PMU, b) a versatile and hardware reconfigurable battery-free wireless sensors equipped with two PMU: AEM30940 and BQ5570 and two rectifiers operating at 868 MHz and 2.45 GHz for wireless power transfer

The experimental setup and testing methodology are also key elements in the implementation of battery-free wireless sensors. First, the dc consumption, estimated in the design

stage, should be carefully evaluated on manufactured prototypes by using appropriate dc measuring setup or embedded/software tools provided by the manufacturers of the systems-on-chip. As example in the case of the BLE-based battery-free wireless sensors [18,19] the power measurement tool of MCUXpresso IDE software provided by NXP was used and the dc consumption profile is represented in Fig. 9. In conjunction with those results, the dc voltage at the input port of the 220 μ F storage capacitor (V_{Cstore}) and at the output of the power management unit (HVOUT) were measured with a high-impedance oscilloscope and the obtained results are depicted in Fig. 10. In order to save dc power, the mode unpaired broadcasting-observer have been selected for BLE communication. The BLE battery-free wireless sensors broadcast the measured data over four advertising events every time when power-up. On each advertising events three separate BLE channels are used for sending the same data. This redundancy (the same data are sending on four separate advertising event and on three different channel) minimize the probability of data loss caused by interference and data collision with other wireless devices operating simultaneously in the same place and over the same frequency band. On network level the data send by the BLE battery wireless sensors are recovered by the Communicating Nodes acting as observer and shared over the Internet.

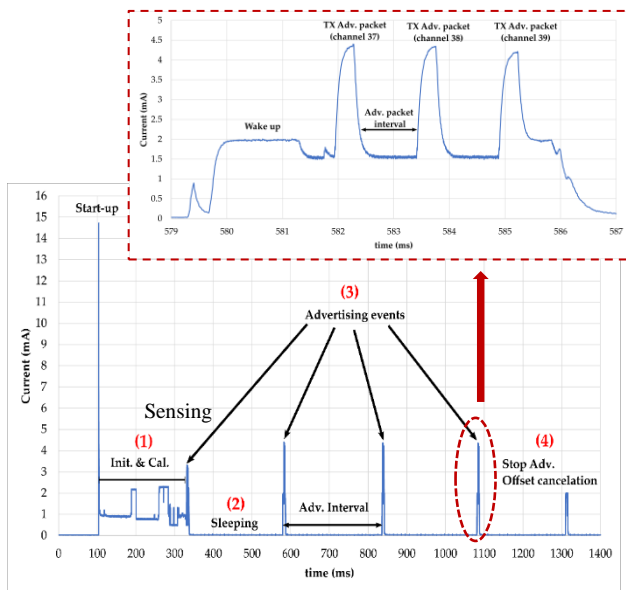

Fig. 9. Dc current consumption profile of the BLE battery-free wireless sensors during sensing and broadcasting obtained with the power measurement tool of MCUXpresso IDE software provided by NXP. The inset is a zoom on the advertising event that consist of a redundant transmission of the same data over three different BLE channels (37, 38 and 39)

The dc voltage results depicted on Fig. 10 highlights the power management implemented by hardware and software configuration at the level of BLE battery-free wireless sensor. As illustrated in Fig. 10 the battery-free wireless sensor can be shut-down (i.e; the storage element -220 μ F capacitor- is empty) and then power-up when an RF power is injected (by radiative wireless power transfer) at the input of the rectifier. This first charge, so-named ‘cold start-up’ procedure is the longest because of the initial empty state of the storage element. Once the storage element is fully charged it is possible to start the periodical operation of the wireless

sensor that is driven by the PMU and by the received RF power. The maximum and minimum threshold voltage level for V_{Cstore} are depending of the PMU used (AEM30940 for the results depicted in Fig. 10) and designer choice. When the maximum threshold value of V_{Cstore} is reach the BLE system-on-chip is start-up and all tasks (initialization, calibration, sensing and advertising) are performed as represented in Fig. 9. PMU shut-down the BLE system-on-chip when the minimum threshold is reach and a periodical operation defined by the second charge time is started as represented in Fig. 10.

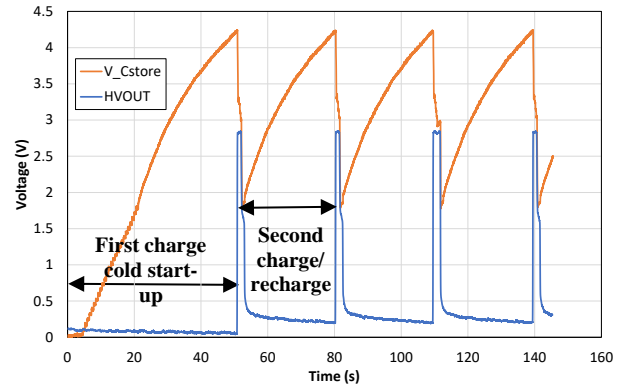

Fig. 10. Measured dc voltage at the input port of the storage capacitor (V_{Cstore}) and at the output of the power management unit (HVOUT) as function of time. Experimental results obtained for a RF power at 6 dBm injected to the rectifier input of BLE battery-free wireless sensor [].

In order to characterize the operation of battery-free wireless sensors several experimental setups were used. First, all the battery-free wireless sensors were characterized inside LAAS-CNRS anechoic chamber for avoiding any interferences and multipath effects. Such a setup is illustrated in Fig. 11 where a minimal network composed of one Communicating Node (driving one RF power source) and three BLE battery-free wireless sensors were characterized.

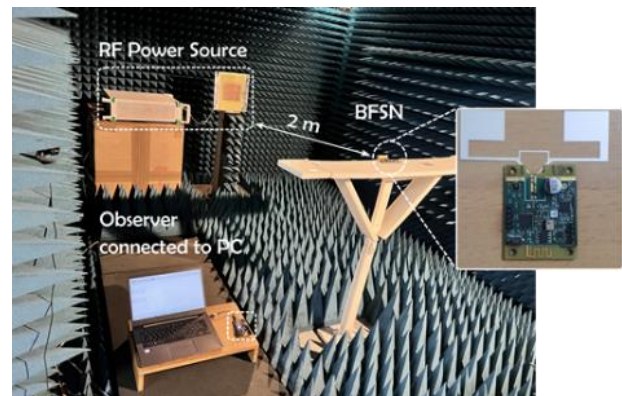

Fig. 11. Experimental setup (inside of anechoic chamber) to characterize a small wireless sensors networks composed of one communicating node (acting as observer and connected to a computer), a RF source and three battery-free BLE wireless sensors

The next step is the characterization of the wireless sensors in a real environment as represented in Fig. 7 where LoRa-based battery-free wireless sensors were characterized inside a concrete beam. On Fig. 12 another setup, specially designed and implemented for testing the new security and identification concept and capabilities [14,15] implemented on wireless power link is presented. By replacing the ‘standard rectifier with a backscattered rectifier [15] commanded with a Manchester encoded private key

generated by the MCU it is possible to generate a backscattering signal used for identification and security purposes containing the same electromagnetic fingerprinting as the power wave generated by the RF source and the private key generated by the MCU of the wireless sensor. This mechanism implemented on the level of wireless power transfer is independent and complementary from the security mechanism implemented by LoRaWAN protocol.

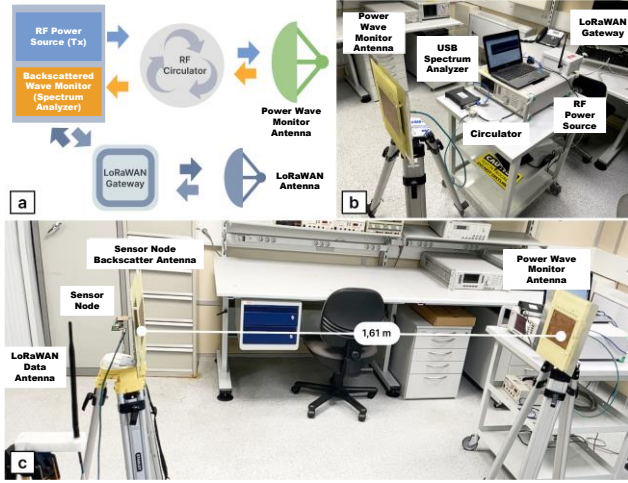

Fig. 12. (a) Communicating Node setup schematic diagram; (b) Photograph of the Communicating Node setup; (c) Photograph of the experimental setup: a LoRa battery-free wireless sensor (Sensing Node) equipped with a backscattering rectifier is illuminated by a power-wave downlink from RF source/Communicating Node and the backscattered-wave signal (uplink) is monitored by the Spectrum Analyzer acting as backscattering wave monitor.

The LoRaWAN battery-free wireless sensor was reprogrammed to initiate a 2 ms identification/security sequence, consisting of two preamble bytes and a 128-bytes private key that is instantaneously Manchester coded by toggling its GPIO with no additional initiation time (MCU was already activated during initialization) and no significant increase in power consumption. Only MCU operates over a

relative short duration and send PVK via GPIO for driving the MOSFET gate of the Backscattering Rectifier, RF part is in sleep mode. The sequence of the tasks performed and the retrieved private key by the spectrum analyzer acting as wave monitor are represented in Fig. 13

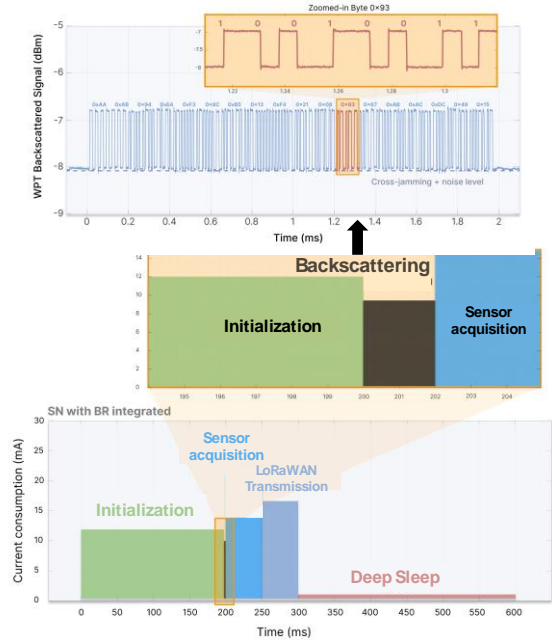

Fig. 13. Sequence diagram of the tasks performed by a LoRa battery-free wireless sensor during a complete process for the sensor equipped with a backscattering rectifier and 'dual' identification/security mechanism implemented on WPT link with a zoom on the backscattering sequence and on the received backscattered 128 bytes private key.

A comparison with state of the art BLE and LoRaWAN battery-free wireless sensors is given in Table II

TABLE II. COMPARISON OF BLE AND LoRaWAN BATTERY-FREE WIRELESS SENSORS POWERED BY WIRELESS POWER TRANSFER WITH STATE-OF-THE-ART

Reference	[20]	[21]	[23]	[24]	[6-8]	[18,19]	[22]
Year	2017	2019	2018	2018	Since 2018		2021
Wireless technology	Bluetooth Low Energy		Bluetooth Low Energy	LoRaWAN	LoRaWAN	Bluetooth Low Energy	LoRaWAN
Sensor(s)	Temperature, humidity; acceleration		Temperature; pressure; acceleration	N/A	Temperature, humidity; dielectric resistivity; mechanical deformation		Acceleration
Application	Rotating machine Structural Health Monitoring		N/A	N/A	Communicating Reinforced Concretes (Structural Health Monitoring)		Automobile engine Structural Health Monitoring
WPT frequency	868 MHz		868 MHz	868 MHz	868 MHz		2.45 GHz
Transmitted power (dBm)	+23 to +35	+34.6	+27	+32.4	+33		+27 (x 2)
Maximum tested range of use (m)	0.5 to 1	1.5	2	1 to 3.2 [non-tested]	11		0.54
Rectifier topology	Two-stage Dickson charge pump		N/A	Doubler	Doubler		Doubler
Cold-start compatibility	YES		YES	N/A	YES		YES
Energy storage	Capacitor		1 mF capacitor	N/A	2.2 mF supercapacitor	220 μ F capacitor	2 x 470 μ F capacitors
Antenna (Gain (dBi))	Patch (+6.7)	Patch (+7.5)	N/A (+1.0)	Log-periodic (+6.0)	Printed folded quarter-wavelength dipole antenna with capacitive arms (+1.54)	Flexible dipole antenna manufactured on PET (N/A)	Patch (+1.8)

Based on authors experience and of the state-of-art some design recommendations for a successful battery-free wireless sensor designs powered by radiative wireless power transfer can be derived:

- it is mandatory to keep the dc consumption as low as possible. This can be implemented by using low-power and ultra-low-power components and communication standard, by shutting-down or putting in sleep-mode all the non-mandatory function/components as soon and as long as possible
- the network topology should be carefully optimized in order to minimize as possible the tasks to be performed by the battery-free wireless sensors
- the power transfer link, in the frame of simultaneous wireless information and power transfer can be used for implementing additional functions (e.g. for roughly controlling the periodicity of the physical measurement or for implementing with a minimal cost in term of consumed energy an additional security and identification mechanism).

IV. CONCLUSION

This paper highlights the main architecture, topology and concept for implementing optimal battery-free wireless sensors network for structural health monitoring and Internet of Things applications. State-of-art designs of battery-free wireless sensors using radiative wireless power transfer and LoRaWAN and BLE communication technologies have been presented. Basic concepts, design recommendations, experimental setup and characterization methodologies have been reviewed with a focus on the experimental results obtained recently by authors. It was proved that the battery-free wireless sensors can be successfully implemented by using commercially available components and communication technologies and with the fully compliance of the actual standard and regulation concerning the use of the ISM frequency bands.

ACKNOWLEDGMENT

This work was partially supported by the French National Research Agency (ANR) under the McBIM project (Communicating Material at the disposal of the Building Information Modeling), grant number ANR-17-CE10-0014, and by the Région Occitanie, France under the OPTENLOC project. The authors acknowledge the support of Alassane Sidibé and Mohamed Abokassem for developing some prototypes presented in this paper.

REFERENCES

- [1] A. Čolaković, and M. Hadžialić, "Internet of Things (IoT): A review of enabling technologies, challenges, and open research issues," *Computer networks*, vol. 144, pp. 17-39, 2018.
- [2] G. Loubet & al. "Wirelessly Powered Battery-Free Sensing Nodes for Internet of Things Applications", unpublished (submitted to IEEE Microwave magazine on June 27, 2024)
- [3] G. Peruzzi, and A. Pozzebon, "A review of energy harvesting techniques for Low Power Wide Area Networks (LPWANs)," *Energies*, vol. 13, no. 13, p. 3433, 2020.
- [4] A. Georgiadis, A. Collado, and M. M. Tentzeris, *Energy Harvesting: Technologies, Systems, and Challenges*, 1st ed., Cambridge, United-Kingdom: Cambridge University Press, p. 208, 2021.
- [5] Palazzi et al., "Radiative Wireless Power Transfer: Where We Are and Where We Want to Go," *IEEE Microwave Magazine*, vol. 24, no. 2, pp. 57-79, Feb. 2023.
- [6] [70] G. Loubet, A. Takacs, and D. Dragomirescu, "Implementation of a Battery-Free Wireless Sensor for Cyber-Physical Systems dedicated to Structural Health Monitoring Applications," *IEEE Access*, vol. 7, pp. 24679-24690, 2019.
- [7] [71] M. David, W. Derigent, G. Loubet, A. Takacs, and D. Dragomirescu, "Communicating Materials: Communicating Concrete Development for Construction Industry," *IEEE Transactions on Industrial Informatics*, 2024.
- [8] [72] G. Loubet, A. Sidibe, P. Herail, A. Takacs, and D. Dragomirescu, "Autonomous Industrial IoT for Civil Engineering Structural Health Monitoring," *IEEE Internet of Things Journal*, vol. 11, no. 5, pp. 8921-8944, 2024.
- [9] [6] European Union, COMMISSION IMPLEMENTING DECISION (EU) 2017/1483 of 8 August 2017 amending Decision 2006/771/EC on harmonisation of the radio spectrum for use by short-range devices and repealing Decision 2006/804/EC, *Official Journal of the European Union*, Decision C(2017) 5464, 2017.
- [10] S. N. Daskalakis, J. Kimionis, A. Collado, G. Goussetis, M. M. Tentzeris, and A. Georgiadis, "Ambient backscatterers using FM broadcasting for low cost and low power wireless applications," *IEEE Transaction on Microwave Theory and Techniques*, vol. 65, no. 12, pp. 5251-5262, 2017.
- [11] N. V. Huynh, D. T. Hoang, X. Lu, D. Niyato, P. Wang, and D. I. Kim, "Ambient Backscatter Communications: A Contemporary Survey," *IEEE Communications Surveys & Tutorials*, vol. 20, no. 4, pp. 2889-2922, 2018.
- [12] R. Torres, R. Correia, and N. B. Carvalho, "All digital ambient backscatter system," in *2020 IEEE Wireless Power Transfer Conference (WPTC)*, pp. 327-330, 15-19 November 2020.
- [13] X. Gu, W. Lin, S. Hemour, and K. Wu, "Readout distance enhancement of battery-free harmonic transponder," *Transaction on Microwave Theory and Techniques*, vol. 69, no. 7, pp. 3413-3424, 2021, doi: 10.1109/TMTT.2021.3068291.
- [14] T. E. Djidjekh, L. Sanogo, G. Loubet, A. Sidibé, D. Dragomirescu, and A. Takacs, "A New Security and Identification Concept for SWIPT Systems in IoT Applications," in *2024 IEEE/MTT-S International Microwave Symposium - IMS 2024*, 16-21 June 2024.
- [15] T. E. Djidjekh, G. Loubet, L. Sanogo, A. Sidibé, Guillaume Delai, D. Dragomirescu, and A. Takacs, "Backscattering Rectifier for Security and Identification in the Context of Simultaneous Wireless Information and Power Transfer," in *2024 EuMC the 54th IEEE European Microwave Conference*, 24-26 September 2024, to be published.
- [16] Okba, A.; Henry, D.; Takacs, A.; Aubert, H. "Autonomous RFID Sensor Node Using a Single ISM Band for Both Wireless Power Transfer and Data Communication". *Sensors* **2019**, *19*, 3330. <https://doi.org/10.3390/s19153330>
- [17] A. Okba, A. Takacs and H. Aubert, "Compact Rectennas for Ultra-Low-Power Wireless Transmission Applications," in *IEEE Transactions on Microwave Theory and Techniques*, vol. 67, no. 5, pp. 1697-1707, May 2019
- [18] A. Sidibe, G. Loubet, A. Takacs, and D. Dragomirescu, "A Multifunctional Battery-Free Bluetooth Low Energy Wireless Sensor Node Remotely Powered by Electromagnetic Wireless Power Transfer in Far-Field," *Sensors*, vol. 22, no. 11, p. 4054, 2022.
- [19] A. Sidibe, G. Loubet, A. Takacs, L. Sanogo, and D. Dragomirescu, "Battery-free Bluetooth Low Energy Wireless Sensor Powered by Radiative Wireless Power Transfer," in *2023 21st IEEE Interregional NEWCAS Conference (NEWCAS)*, Edinburgh, Scotland, IEEE, pp. 1-4, 2023.
- [20] J. Janhunen, K. Mikhaylov, and J. Petäjajarvi, "Experimental RF-signal based wireless energy transmission," in *EuCNC The IEEE European Conference on Networks and Communications*, pp. 1-6, 2017.
- [21] J. Janhunen, K. Mikhaylov, J. Petäjajarvi, and M. Sonkki, "Wireless energy transfer powered wireless sensor node for green IoT: Design, implementation and evaluation," *Sensors*, vol. 19, no. 1, p. 90, 2019.
- [22] G. Paolini, D. Masotti, M. Guermami, M. Shanawani, L. Benini, and A. Costanzo, "An Ambient-Insensitive Battery-Less Wireless Node for Simultaneous Powering and Communication," in *EuMC The 50th IEEE European Microwave Conference*, pp. 522-525, 2021.
- [23] A. N. Parks, A. P. Sample, Y. Zhao, and J. R. Smith, "A wireless sensing platform utilizing ambient RF energy," in *2013 IEEE Topical Conference on Biomedical Wireless Technologies, Networks, and Sensing Systems*, IEEE, pp. 154-156, January 2013.
- [24] E. M. Jung, Y. Cui, T. H. Lin, X. He, A. Eid, J. G. Hester, G. D. Abowd, T. E. Starner, W. S. Lee, and M. M. Tentzeris, "A wideband, quasi-isotropic, kilometer-range fm energy harvester for perpetual IoT," *IEEE Microwave and Wireless Components Letters*, vol. 30, no. 2, pp. 201-204, 2019.